

# BUNN®

## Ultra™ Frozen Beverage System with 2 Hoppers

## Liquid Autofill with Internal Brixing System

ITEM# \_\_\_\_\_

PROJECT \_\_\_\_\_

DATE \_\_\_\_\_



### Ultra-2 CF Valve

Dimensions:

31.9"H x 16"W x 27.5"D

(81 cm H x 40.6 cm W x 69.9 cm D)

## Features

### Ultra Gourmet Ice® System

**New liquid autofill with internal brixing to allow interfacing with standard bag-in-the-box pumping**

- Constant flow control for accurate brixing of product.
- Simple brix adjustment.
- Reversing auger design quickens freeze time and reduces air mixing.
- Very simple to program and run with touchpad display, which also guides cleaning and preventive maintenance.
- Refrigeration system internally monitored to ensure long lasting performance.
- Two large 3 gallon (11.4 litre) hoppers for optimum cooling and serving capacity.
- Full 2-year parts and 1-year labor warranty. 5-year parts and 1-year labor warranty on compressor and 3-year parts and labor warranty on electronics. See the product manual for additional details.
- Sanitation listed by NSF to Standard 6 and 18 (including dairy & alcohol) and safety listed by ETL to UL Standard (UL 471) and CSA Standard (C22.2 No. 120).
- International electrical configurations available.
- Preventive maintenance kit: 34245.0000. 

### Partial PM Kit contents:

- (4) LAMP, T-5 WEDGEBASE MINI 12173
- (2) BUSHING, HOPPER - AUGER
- (2) SEAL, COOLING DRUM TO SHAFT
- (2) SEAL, COOLING DRUM TO HOPPER
- (2) SEAL, FAUCET - FLAT SILICON
- (1) KIT, KRYTOX GREASE
- (1) INSTRUCTIONS

### View of Liquid Autofill Assembly



For current specification sheets and other information, go to [www.bunn.com](http://www.bunn.com).

International models may vary in appearance.

## Related Products

### Conversion Kits - Pourover to Autofill System (includes hoppers)

Product No.: 44071.0101

Kit, CFV Upgrade, w/hoppers (Ultra-2 black)

Product No.: 44071.0102

Kit, CFV Upgrade, w/hoppers (Ultra-2 white)

### Conversion Kits - Brix Pump System to new Autofill System (includes hoppers)

Product No.: 44071.0104

Kit, Retrofit CFV, w/hoppers (Ultra-2 black)

Product No.: 44071.0105

Kit, Retrofit CFV, w/hoppers (Ultra-2 white)

### Conversion Kits - Brix Pump System to new Autofill System (does not include hoppers)

Product No.: 44071.0004

Kit, Convert LAF to CFV, no hoppers (Ultra-2 black)

Product No.: 44070.0005

Kit, Retrofit CFV, no hoppers (Ultra-2 white)



### Ultra-2 Lid Lock Kit

Part Number: 34996.0000 (white)

Part Number: 34996.0001 (black)

### Ultra-2 Lid Lock and Handle Lock Kit

Part Number: 34996.0002 (white)

Part Number: 34996.0003 (black)

### Ultra-2 Handle Lock Kit

Part Number: 34996.0004 (white & black)

### Model

ULTRA-2 CFV

### Agency Listing



## Dimensions & Specifications

Model	Product #	Volts	Amps	Capacity	Cubic Measure	Shipping Weight	Cord Attached
ULTRA-2 CFV (Stainless/White)	34000.0521	120	12	2 Hoppers@3.0 gal each	14.9 ft <sup>3</sup>	137 lbs.	Yes*
ULTRA-2 CFV (Stainless/Black)	34000.0522	120	12	2 Hoppers@3.0 gal each	14.9 ft <sup>3</sup>	137 lbs.	Yes*
ULTRA-2 CFV (All Black)	34000.0520	120	12	2 Hoppers@3.0 gal each	14.9 ft <sup>3</sup>	137 lbs.	Yes*

\*Power cord (NEMA 5-15P) 15 Amp-120V machine only. \*\*Flat lid. †20 day item.

Electrical: Models require 2-wires plus ground service rated 120V, single phase, 60 Hz.

Operating water pressure 30-80psi.

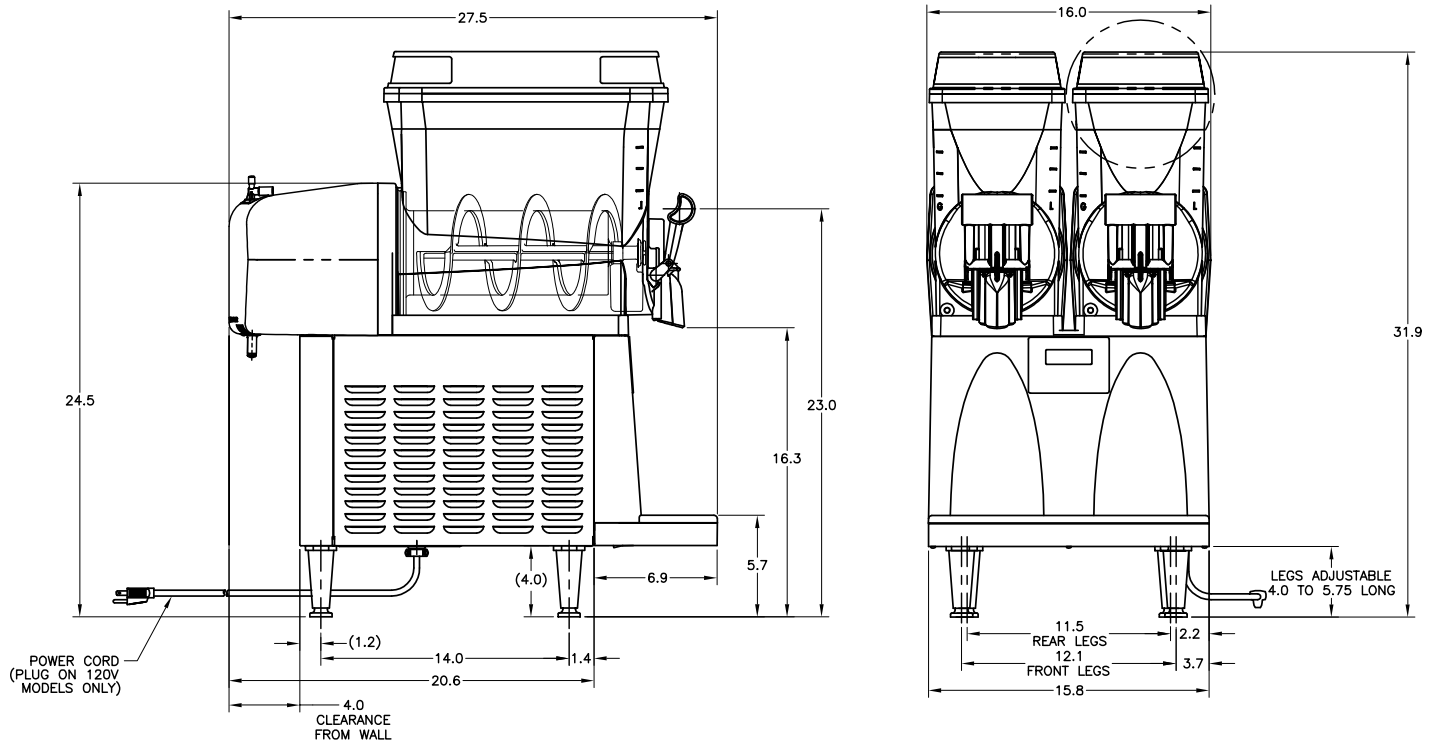
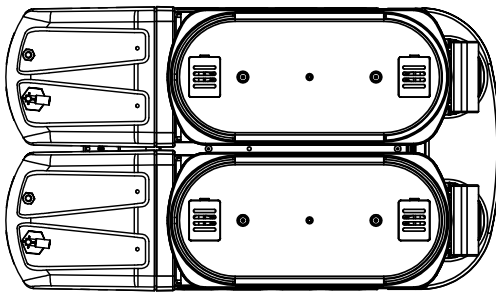

Bunn-O-Matic® Corporation - 1400 Stevenson Drive Springfield, Illinois 62703 • 800-637-8606 • 217-529-6601 • Fax 217-529-6644 • www.bunn.com

BUNN® practices continuous product research and improvement. We reserve the right to change specifications and product design without notice. Such revisions do not entitle the buyer to corresponding changes, improvements, additions or replacements for previously purchased equipment.

All dimensions shown in inches.

9/11 © Bunn-O-Matic Corporation