

BUNN®

TU5Q

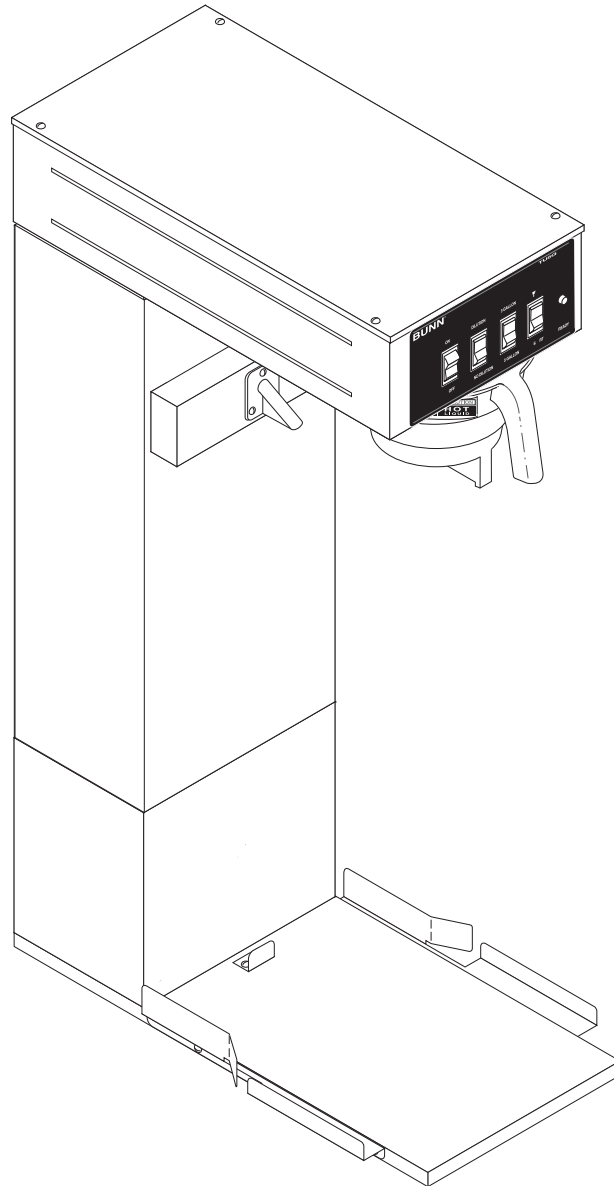

OPERATING & SERVICE MANUAL

BUNN-O-MATIC CORPORATION

POST OFFICE BOX 3227

SPRINGFIELD, ILLINOIS 62708-3227

PHONE: (217) 529-6601 FAX: (217) 529-6644



BUNN-O-MATIC COMMERCIAL PRODUCT WARRANTY

Bunn-O-Matic Corp. ("BUNN") warrants equipment manufactured by it as follows:

- 1) Airpots, thermal carafes, decanters, GPR servers, iced tea/coffee dispensers, MCP/MCA pod brewers thermal servers and Thermofresh servers (mechanical and digital)- 1 year parts and 1 year labor.
- 2) All other equipment - 2 years parts and 1 year labor plus added warranties as specified below:
 - a) Electronic circuit and/or control boards - parts and labor for 3 years.
 - b) Compressors on refrigeration equipment - 5 years parts and 1 year labor.
 - c) Grinding burrs on coffee grinding equipment to grind coffee to meet original factory screen sieve analysis - parts and labor for 4 years or 40,000 pounds of coffee, whichever comes first.

These warranty periods run from the date of installation BUNN warrants that the equipment manufactured by it will be commercially free of defects in material and workmanship existing at the time of manufacture and appearing within the applicable warranty period. This warranty does not apply to any equipment, component or part that was not manufactured by BUNN or that, in BUNN's judgment, has been affected by misuse, neglect, alteration, improper installation or operation, improper maintenance or repair, non periodic cleaning and descaling, equipment failures related to poor water quality, damage or casualty. In addition, the warranty does not apply to replacement of items subject to normal use including but not limited to user replaceable parts such as seals and gaskets. This warranty is conditioned on the Buyer 1) giving BUNN prompt notice of any claim to be made under this warranty by telephone at (217) 529-6601 or by writing to Post Office Box 3227, Springfield, Illinois 62708-3227; 2) if requested by BUNN, shipping the defective equipment prepaid to an authorized BUNN service location; and 3) receiving prior authorization from BUNN that the defective equipment is under warranty.

THE FOREGOING WARRANTY IS EXCLUSIVE AND IS IN LIEU OF ANY OTHER WARRANTY, WRITTEN OR ORAL, EXPRESS OR IMPLIED, INCLUDING, BUT NOT LIMITED TO, ANY IMPLIED WARRANTY OF EITHER MERCHANTABILITY OR FITNESS FOR A PARTICULAR PURPOSE. The agents, dealers or employees of BUNN are not authorized to make modifications to this warranty or to make additional warranties that are binding on BUNN. Accordingly, statements by such individuals, whether oral or written, do not constitute warranties and should not be relied upon.

If BUNN determines in its sole discretion that the equipment does not conform to the warranty, BUNN, at its exclusive option while the equipment is under warranty, shall either 1) provide at no charge replacement parts and/or labor (during the applicable parts and labor warranty periods specified above) to repair the defective components, provided that this repair is done by a BUNN Authorized Service Representative; or 2) shall replace the equipment or refund the purchase price for the equipment.

THE BUYER'S REMEDY AGAINST BUNN FOR THE BREACH OF ANY OBLIGATION ARISING OUT OF THE SALE OF THIS EQUIPMENT, WHETHER DERIVED FROM WARRANTY OR OTHERWISE, SHALL BE LIMITED, AT BUNN'S SOLE OPTION AS SPECIFIED HEREIN, TO REPAIR, REPLACEMENT OR REFUND.

In no event shall BUNN be liable for any other damage or loss, including, but not limited to, lost profits, lost sales, loss of use of equipment, claims of Buyer's customers, cost of capital, cost of down time, cost of substitute equipment, facilities or services, or any other special, incidental or consequential damages.

392, AutoPOD, AXIOM, BrewLOGIC, BrewMETER, Brew Better Not Bitter, BrewWISE, BrewWIZARD, BUNN Espresso, BUNN Family Gourmet, BUNN Gourmet, BUNN Pour-O-Matic, BUNN, BUNN with the stylized red line, BUNNlink, Bunn-OMatic, Bunn-O-Matic, BUNNserve, BUNNSERVE with the stylized wrench design, Cool Froth, DBC, Dr. Brew stylized Dr. design, Dual, Easy Pour, EasyClear, EasyGard, FlavorGard, Gourmet Ice, Gourmet Juice, High Intensity, iMIX, Infusion Series, Intellisteam, My Café, Phase Brew, PowerLogic, Quality Beverage Equipment Worldwide, Respect Earth, Respect Earth with the stylized leaf and coffee cherry design, Safety-Fresh, savemycoffee.com, Scale-Pro, Silver Series, Single, Smart Funnel, Smart Hopper, SmartWAVE, Soft Heat, SplashGard, The Mark of Quality in Beverage Equipment Worldwide, ThermoFresh, Titan, trifecta, Velocity Brew, A Partner You Can Count On, Air Brew, Air Infusion, Beverage Bar Creator, Beverage Profit Calculator, Brew better, not bitter., BUNNSource, Coffee At Its Best, Cyclonic Heating System, Daypart, Digital Brewer Control, Nothing Brews Like a BUNN, Pouring Profits, Signature Series, Tea At Its Best, The Horizontal Red Line, Ultra are either trademarks or registered trademarks of Bunn-O-Matic Corporation.

CONTENTS

Introduction	2
Warranty	2
User Notices	3
Electrical Requirements	4
Plumbing Requirements	4
Initial Set-Up	5
Operating Controls	6
Cleaning	6
Tea Brewing	6
Troubleshooting	7
Service	12
Wiring Diagrams	23

INTRODUCTION

This equipment will brew a three or five-gallon batch of fresh tea into an awaiting dispenser. The tea will be dispensed at approximately room temperature to conserve ice. The brewer is only for indoor use on a sturdy counter or shelf and requires a minimum of 40 inches of clearance above the counter.

USER NOTICES

Carefully read and follow all notices on the equipment and in this manual. They were written for your protection. All notices on the equipment should be kept in good condition. Replace any unreadable or damaged labels.

#00831.0000

 WARNING
<ul style="list-style-type: none">◆ Fill water tank before turning - on - thermostat or connecting appliance to power source.◆ Use only on a properly protected circuit capable of the rated load.◆ Electrically ground the chassis.◆ Follow national/local electrical codes.◆ Do not use near combustibles.
FAILURE TO COMPLY RISKS EQUIPMENT DAMAGE, FIRE, OR SHOCK HAZARD
READ THE ENTIRE OPERATING MANUAL BEFORE BUYING OR USING THIS PRODUCT
THIS APPLIANCE IS HEATED WHENEVER CONNECTED TO A POWER SOURCE
<small>00831.0000F 3/98 ©1998 BUNN-O-MATIC CORPORATION</small>

#00656.0001

<p>As directed in the International Plumbing Code of the International Code Council and the Food Code Manual of the Food and Drug Administration (FDA), this equipment must be installed with adequate backflow prevention to comply with federal, state and local codes. For models installed outside the U.S.A., you must comply with the applicable Plumbing /Sanitation Code for your area.</p>

#03408.0000

	<table border="1"><thead><tr><th> WARNING</th></tr></thead><tbody><tr><td>REMOVE FUNNEL SLOWLY</td></tr></tbody></table>	 WARNING	REMOVE FUNNEL SLOWLY
 WARNING			
REMOVE FUNNEL SLOWLY			

#03409.0000

	<table border="1"><thead><tr><th> WARNING</th></tr></thead><tbody><tr><td>HOT LIQUID</td></tr></tbody></table>	 WARNING	HOT LIQUID
 WARNING			
HOT LIQUID			

ELECTRICAL REQUIREMENTS

CAUTION - The brewer must be disconnected from the power source until specified in *Initial Set-Up*.

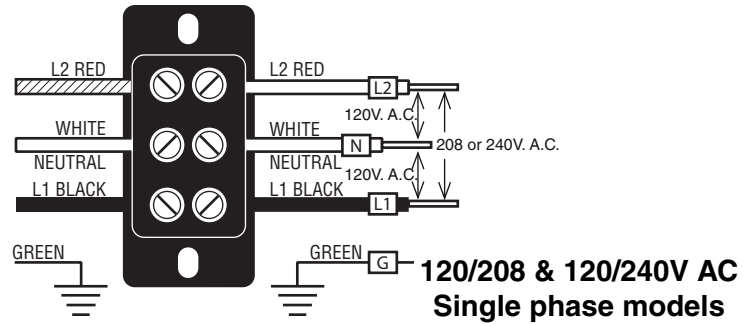
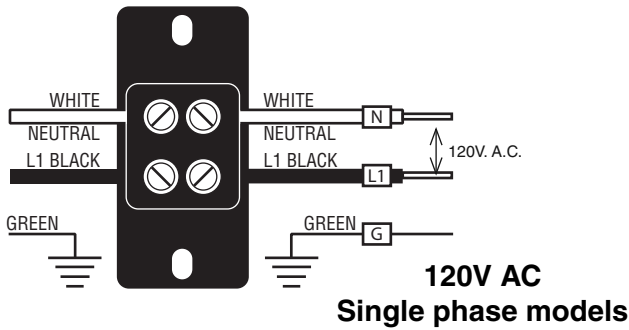

The brewer requires either 2-wire, grounded service rated 120 volts ac, or 3-wire, grounded service rated 120/208 or 120/240 volts ac, 20 amp, single phase, 60 Hz. Refer to the product's dataplate above the dilution nozzle for actual voltage of your particular brewer model.

Electrical Hook-Up

CAUTION – Improper electrical installation will damage electronic components.

1. An electrician must provide electrical service as specified.
2. Remove top lid and rotate the control thermostat knob fully counterclockwise to the "OFF" position and replace top lid.
3. Remove the lower rear panel, feed the cord through the strain relief at the rear of the brewer and connect it to the terminal block.
4. Using a voltmeter, check the voltage and color coding of each conductor at the electrical source.
5. Connect the brewer to the power source and verify voltage at the terminal block.
6. If plumbing is to be hooked up later be sure the brewer is disconnected from the power source. If plumbing has been hooked up, the brewer is ready for *Initial Set-Up*.

WARNING - The brewer must be electrically grounded using the green screw near the terminal block. Do not assume a plumbing line will provide an adequate ground.

PLUMBING REQUIREMENTS

The brewer must be connected to a cold water system with operating pressure between 30 and 90 psi(207 and 621 kPa) from a 1/2" or larger supply line. A shut-off valve should be installed in the line before the brewer. Install a regulator in the line when pressure is greater than 90 psi(621 kPa) to reduce it to 50 psi(345 kPa). The water inlet fitting is 1/4" flare.

NOTE - Bunn-O-Matic recommends 1/4" copper tubing for installations of less than 25 feet and 3/8" for more than 25 feet from the 1/2" water supply line. A tight coil of copper tubing in the water line will facilitate moving the brewer to clean the countertop. Bunn-O-Matic does not recommend the use of a saddle valve to install the brewer. The size and shape of the hole made in the supply line by this type of device may restrict water flow.

As directed in the International Plumbing Code of the International Code Council and the Food Code Manual of the Food and Drug Administration (FDA), this equipment must be installed with adequate backflow prevention to comply with federal, state and local codes. For models installed outside the U.S.A., you must comply with the applicable Plumbing /Sanitation Code for your area.

1. Attach the female fitting from the short piece of tubing on the strainer/flow control (supplied) to the water inlet fitting at the rear of the brewer.
2. Flush the water line and securely attach it to the flare fitting on the strainer/flow control.
3. Turn on the water supply.

INITIAL SET-UP

CAUTION - The brewer must be disconnected from the power source throughout the *Initial Set-Up*, except when specified in the instructions.

1. Remove the top lid from the brewer.
2. Rotate the control thermostat knob fully counterclockwise to the "OFF" position. Set the three-gallon timer knob at 4 minutes, the five-gallon timer knob at 6 3/4 minutes, and replace the top lid.
3. Insert an empty funnel into the funnel rails.
4. Place an empty dispenser on the brewer base.
5. Connect the brewer to the power source. Place the On/Off switch in the lighted "ON" position, the dilution switch in the "NO DILUTION" position, the batch selector in the "FIVE GALLON" position, and momentarily press the start switch. Water will flow into the tank for approximately 6 3/4 minutes. Press the start switch again to initiate a second cycle. When the second cycle stops, press the start switch once more. During the third cycle, the tank will fill to its capacity and the excess will flow from the funnel into the dispenser. Empty the dispenser when the flow of water from the funnel stops.
6. Place the dilution switch in the "DILUTION" position and press the start switch to begin another brew cycle. When the flow of water stops, measure the total water volume from the dispenser. It should be approximately 5 gallons and 15 ounces. (655 ounces.)
7. If not, disconnect the brewer from the power source, remove the top lid, and adjust the five gallon timer knob up or down, as required.
8. Replace the top lid, connect the brewer to the power source, start, and measure another cycle.
9. Repeat steps 6-8 until the recommended total water volume (655 ounces) is achieved.
10. Place the batch selector in the "THREE GALLON" position and press the start switch to begin another brew cycle. When the flow of water stops, measure the total water volume from the dispenser. It should be approximately 3 gallons and 9 ounces. (393 ounces)
11. If not, disconnect the brewer from the power source, remove the top lid, and adjust the three gallon timer knob up or down, as required.
12. Replace the top lid, connect the brewer to the power source, start, and measure another cycle.
13. Repeat steps 10-12 until the recommended total water volume (393 ounces) is achieved.
14. The concentrate is pre-adjusted to deliver the correct ratio of water over the funnel to dilution water.
15. Disconnect the brewer from the power source, remove the top lid, rotate the control thermostat knob fully clockwise to the "ON" position and replace the top lid.
16. Empty the dispenser.
17. Connect the brewer to the power source and wait for the water in the tank to heat to brewing temperature (approximately 20 minutes). Some water will drip from the funnel during this time; this is due to expansion and should not occur thereafter.
18. Begin another brew cycle. Empty the reservoir after water has stopped flowing from the funnel.
19. Allow the water in the tank to heat to the proper temperature.
20. The brewer is now ready to brew approximately 3 or 5 gallons of freshly brewed room temperature tea using approximately 1 ounce of loose leaves per gallon of finished iced tea.

OPERATING CONTROLS

A. Lighted ON/OFF Switch

ON - Placing the switch in the lighted upper position allows the start switch to activate a timed brew cycle.

OFF - Placing the switch in the lower position stops the brew cycle. Stopping a brew cycle after it has been started will not stop the flow of water into the funnel until the tank syphons down to its proper level. **The switch should always be placed in this position after a brew cycle and whenever the brewer is unattended.**

B. Dilution/No Dilution Selector Switch

Dilution - Placing the switch in the upper position produces fully diluted iced tea from the brew cycle.

No Dilution - Placing the switch in the lower position produces only tea concentrate that will need to be diluted in another manner before it is ready to serve.

C. 3-Gallon/5-Gallon Selector Switch

3-Gallon - Placing the switch in the upper position produces three gallons of iced tea (set on "DILUTION") or 76 oz. of iced tea concentrate (set on "NO DILUTION") from the brew cycle.

5-Gallon - Placing the switch in the lower position produces five gallons of iced tea (set on "DILUTION") or 126 oz. of iced tea concentrate (set on "NO DILUTION") from the brew cycle.

D. Start Switch

Starts a brew cycle when the ON/OFF switch is in the "ON" position.

CLEANING

CAUTION - CLEAN AND SANITIZE YOUR ICED TEA BREWER DAILY

1. Remove and thoroughly clean the entire brew funnel. The funnel tip and screen must be free from any tea particles or residue. Reassemble the funnel.
2. Unplug the brewer. Remove and thoroughly rinse the sprayhead. The holes must be open and clear of any mineral deposits. Wipe the sprayhead panel clean with a damp cloth.
3. Insert the delimiting spring into the sprayhead fitting until no more than one inch is visible and move it in and out 5 or 6 times. Reattach the sprayhead.
4. Wash the entire outside surface of the brewer with a clean damp cloth.

CAUTION - DO NOT KEEP BREWED ICED TEA OVERNIGHT. THE SERVER MUST BE CLEANED DAILY.

TEA BREWING

1. Begin each brew cycle with a clean empty brew funnel and server. (Be sure the server lid doesn't interfere with the flow of dilution water.)
2. Insert a BUNN® filter into the funnel.
3. Pour the packet of loose fresh tea leaves into the filter. Approximately one ounce is recommended for each gallon of finished beverage.
4. Level the bed of tea leaves by gently shaking.
5. Slide the funnel into the funnel rails until it stops.
6. Place the ON/OFF switch in the "ON" position.
7. Place the batch selector switch in the desired position.
8. Place the dilution switch in the desired position.
9. Momentarily press the start switch.

CAUTION - The funnel contains hot liquids. Remove funnel slowly.

10. Carefully remove the brew funnel and discard the used filter when tea no longer drips from the funnel tip.
11. Place the ON/OFF switch in the "OFF" position to prevent a false start.
12. Fresh tea is available at the faucet.

TROUBLESHOOTING

A troubleshooting guide is provided to suggest probable causes and remedies for the most likely problems encountered. If the problem remains after exhausting the troubleshooting steps, contact the Bunn-O-Matic Technical Service Department.

- Inspection, testing, and repair of electrical equipment should be performed only by qualified service personnel.
- All electronic components have 120 volt ac and low voltage dc potential on their terminals. Shorting of terminals or the application of external voltages may result in board failure.
- Intermittent operation of electronic circuit boards is unlikely. Board failure will normally be permanent. If an intermittent condition is encountered, the cause will likely be a switch contact or a loose connection at a terminal or crimp.
- Solenoid removal requires interrupting the water supply to the valve. Damage may result if solenoids are energized for more than ten minutes without a supply of water.
- The use of two wrenches is recommended whenever plumbing fittings are tightened or loosened. This will help to avoid twists and kinks in the tubing.
- Make certain that all plumbing connections are sealed and electrical connections tight and isolated.
- This brewer is heated at all times. Keep away from combustibles.

WARNING –

- Exercise extreme caution when servicing electrical equipment.
- Unplug the brewer when servicing, except when electrical tests are specified.
- Follow recommended service procedures
- Replace all protective shields or safety notices

Problem	Probable Cause	Remedy
Brew cycle will not start	1. No water	Water lines and valves to the brewer must be open.
	2. No power or incorrect voltage to the brewer	Check circuit breakers or fuses.
	3. External Strainer/Flow Control (.750 GPM)	(A) Direction of flow arrow must be pointing towards the brewer. (B) Remove the strainer/flow control and check for obstructions. Clear or replace.
	4. ON/OFF Switch	Refer to <i>Service</i> - ON/OFF Switch for testing. See page 20
	5. Start Switch	Refer to <i>Service</i> - Start Switch for testing procedures. See page 21

TROUBLESHOOTING (cont.)

PROBLEM

Brew cycle will not start (cont.)

PROBABLE CAUSE

6. Brew Timer
7. Brew Solenoid Valve

REMEDY

Refer to *Service* - Brew Timer for testing procedures. See page 15

Refer to *Service* - Brew Solenoid Valve for testing procedures. See page 14

Water is not hot

1. Limit Thermostat
CAUTION - Do not eliminate or bypass limit thermostat or thermal cut-off. Use only BOM replacement part #29329.1000

Refer to *Service* - Limit Thermostat for testing procedures. See page 19

2. Control Thermostat

Refer to *Service* - Control Thermostat for testing procedures. See page 16

3. Tank Heater

Refer to *Service* - Tank Heater for testing procedures. See page 22

Dilution cycle will not start

1. ON/OFF Switch

Refer to *Service* - ON/OFF Switch for testing procedures. See page 20

2. Start Switch

Refer to *Service* - Start Switch for testing procedures. See page 21

3. Dilution Switch

Refer to *Service* - Dilution Switch for testing procedures. See page 18

TROUBLESHOOTING (cont.)

PROBLEM

Inconsistent beverage level in dispenser

PROBABLE CAUSE

1. Syphon System

REMEDY

The brewer must be level or slightly lower in front to syphon properly.

2. Lime Build-up

CAUTION - Tank and tank components should be delimed regularly depending on local water conditions. Excessive mineral build-up on stainless steel surfaces can initiate corrosive reactions resulting in serious leaks.

Inspect the tank assembly for excessive lime deposits. Delime as required.

3. Water Pressure

The water pressure to the brewer must be at least 20 psi(138 kPa).

Consistently high or low beverage level in the dispenser

1. External Strainer/Flow Control (.750 GPM)

(A) Direction of flow arrow must be pointing towards brewer.

(B) Remove the strainer/flow control and check for obstructions. Clear or replace.

Spitting or excessive steaming

1. Lime Build-up

CAUTION - Tank and tank components should be delimed regularly depending on local water conditions. Excessive mineral build-up on stainless steel surfaces can initiate corrosive reactions resulting in serious leaks.

Inspect tank assembly for excessive lime deposits. Delime as required.

2. Control Thermostat

Refer to *Service* - Control Thermostat for testing procedures. See page 16

Drip-out time too long

1. Funnel Tip

The brew funnel should be cleaned thoroughly before each brew cycle to lessen the chance of tea leaf particles clogging the drip-out tip.

TROUBLESHOOTING (cont.)

PROBLEM

PROBABLE CAUSE

REMEDY

Dripping from sprayhead

1. Syphon System

The brewer must be level or slightly lower in front to syphon properly.

2. Lime Build-up

CAUTION - Tank and tank components should be delimed regularly depending on local water conditions. Excessive mineral build-up on stainless steel surfaces can initiate corrosive reactions resulting in serious leaks.

Inspect the tank assembly for excessive lime deposits. Delime as required.

3. Brew Solenoid Valve

Refer to *Service* - Brew Solenoid Valve for testing procedures. See page 14

Water flows into tank continuously (ON/OFF Switch "ON")

1. Brew Timer

Refer to *Service* - Brew Timer for testing procedures. See page 15

Water flows into tank continuously (ON/OFF Switch "OFF")

1. Brew Solenoid Valve

Refer to *Service* - Brew Solenoid Valve for testing procedures. See page 14

Beverage overflows dispenser

1. Dispenser

The dispenser must be completely empty before starting a brew cycle.

2. Brew Timer

Refer to *Service* - Brew Timer for testing procedures. See page 15

3. Brew Solenoid Valve

Remove the Brew Solenoid Valve and clean any obstruction. Rebuild or replace the valve if necessary. See page 14

Weak beverage

1. Filter Type

BUNN® paper filters must be used for proper extraction.

2. Tea

A sufficient quantity of fresh, loose tea leaves should be used for proper extraction.

3. Sprayhead

A six-hole stainless steel sprayhead must be used for proper extraction.

TROUBLESHOOTING (cont.)

PROBLEM

PROBABLE CAUSE

REMEDY

Weak beverage (cont.)

4. Funnel Loading

The BUNN® paper filter must be centered in the funnel and the bed of tea leaves leveled by gentle shaking.

5. Water Temperature

Place an empty funnel on an empty dispenser beneath the sprayhead. Initiate a brew cycle and check the water temperature immediately below the sprayhead with a thermometer. The reading should not be less than 200°F. Adjust the control thermostat to increase the water temperature. Replace if necessary.

6. Low Brew Water Volume

Adjust needle valve to achieve 76 oz. water from the sprayhead when the batch size setting is at three gallons. To increase volume, turn counter-clockwise. To decrease volume, turn clockwise.

Dry tea leaves remain in the funnel

1. Funnel Loading

The BUNN® paper filter must be centered in the funnel and the bed of tea leaves leveled by gently shaking.

Brewer is making unusual noises

1. Solenoid(s)

The nut on the solenoid(s) must be tight or it will vibrate during operation.

2. Plumbing Lines

Plumbing lines should not be resting on the counter top.

3. Water Supply

(A) The brewer must be connected to a cold water line.

(B) Water pressure to the brewer must not exceed 90 psi(621 kPa). Install a regulator if necessary to lower the working pressure to approximately 50 psi(345 kPa).

4. Tank Heater

Remove and clean lime off the tank heater. See page 22

SERVICE

This section provides procedures for testing and replacing various major components used in this brewer should service become necessary. Refer to *Troubleshooting* for assistance in determining the cause of any problem.

WARNING - Inspection, testing, and repair of electrical equipment should be performed only by qualified service personnel. The brewer should be disconnected from the power source when servicing, except when electrical tests are required and the test procedure specifically states to plug-in the brewer.

COMPONENT ACCESS

WARNING - Disconnect the brewer from the power source before the removal of any panel or the replacement of any component.

All components are accessible by the removal of the top cover and rear inspection panel.

The top cover is attached with four #6-32 screws. Removal of the top cover will allow access to ON/OFF switch, start switch, batch selector switch, dilution switch, brew timer, control thermostat, limit thermostat and tank heater.

The rear inspection panel is attached with six #8-32 screws. Removal of the rear panel will allow access to the brew solenoid, dilution solenoid and terminal block.

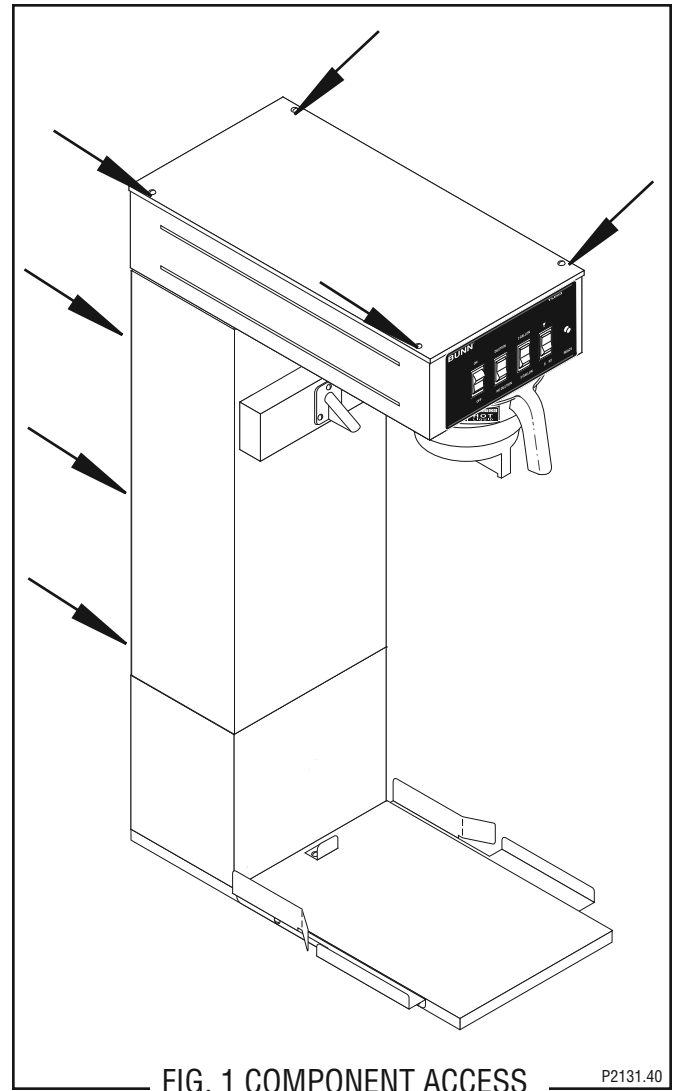

FIG. 1 COMPONENT ACCESS

P2131.40

Contents

Batch Selector Switch	13
Brew Solenoid Valve	14
Brew Timer	15
Control Thermostat	16
Dilution Solenoid Valve	17
Dilution Switch	18
Limit Thermostat	19
ON/OFF Switch	20
Start Switch	21
Tank Heater	22
Wiring Diagram	23

SERVICE (cont.)

BATCH SELECTOR SWITCH

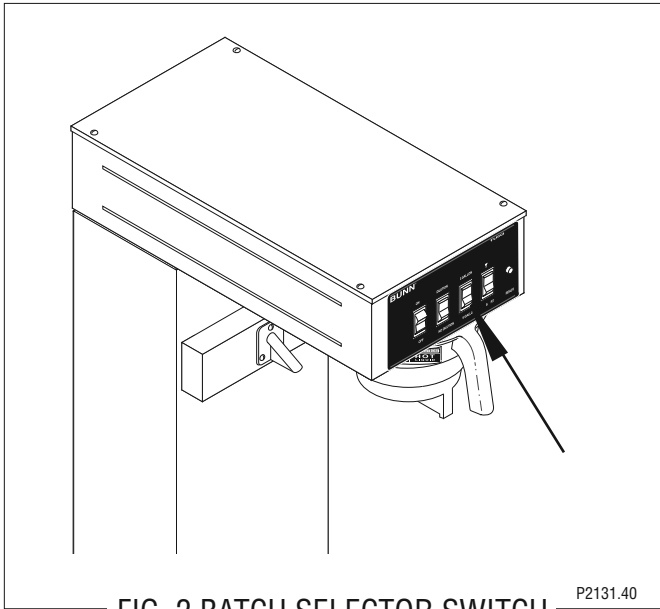

FIG. 2 BATCH SELECTOR SWITCH

Location:

The batch selector switch is located in the front of the hood, above and to the right of the brew funnel. It is the second switch from the right.

Testing Procedures:

1. Disconnect the brewer from the power source.
2. Remove the wires from all terminals.
3. Select the 3-gallon setting.
4. Check for continuity between the terminals where the orange and green wires connect to the switch. Continuity should be present across these terminals.

If continuity is present as described, reconnect the wires. The switch is operating properly. If continuity is not present as described, replace the switch.

5. Select the 5-gallon setting.
6. Check for continuity between the terminals where the orange and yellow wires connect to the switch. Continuity should be present.

If continuity is present as described, reconnect the wires, the switch is operating properly. If continuity is not present as described, replace the switch.

Removal and Replacement:

1. Remove the wires from the switch terminals.
2. Compress the clips inside the hood and gently push the switch through the opening.
3. Push the new switch into the opening and spread the clips to hold the switch captive in the hood.
4. Refer to Fig. 3 when reconnecting the wires.

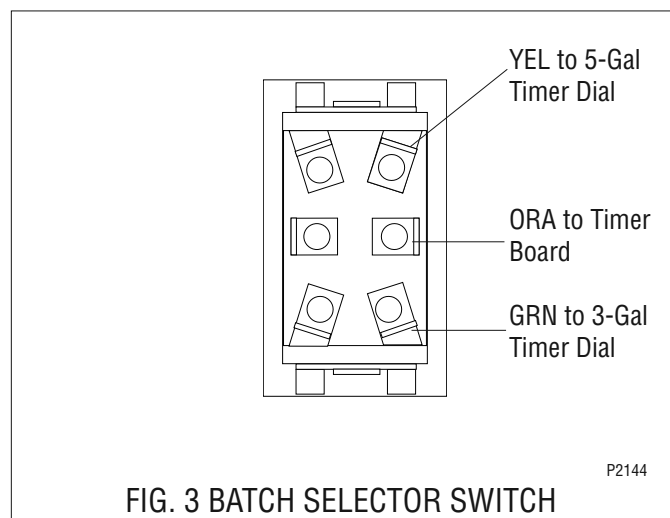

FIG. 3 BATCH SELECTOR SWITCH
TERMINALS

SERVICE (cont.)
BREW SOLENOID VALVE

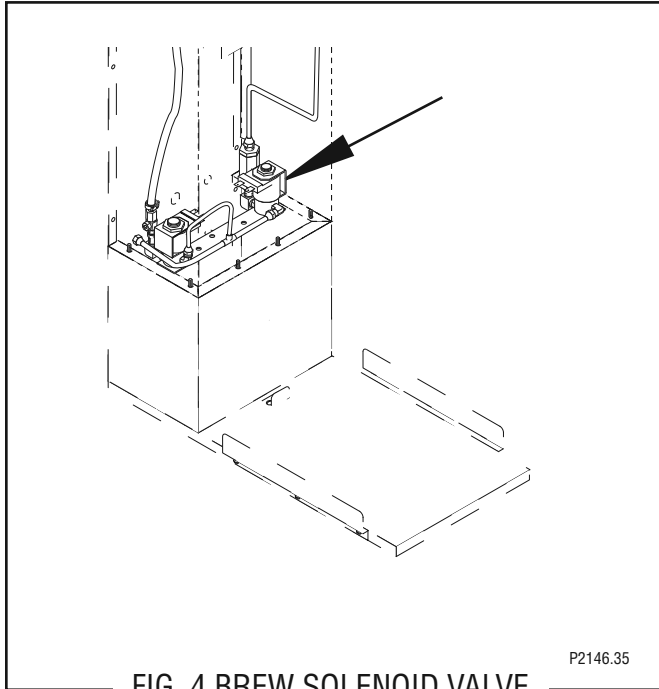

FIG. 4 BREW SOLENOID VALVE

Location:

The brew solenoid is located inside the upper rear access panel, on the left side of the bracket when looking at it from the rear of the brewer

Test Procedures:

1. Disconnect the brewer from the power source.
2. Disconnect the white/violet and white/green wires from the solenoid valve. With the ON/OFF switch in the "ON" position press the start switch.
3. With a voltmeter, check the voltage across the white/violet and white/green wires. Connect the brewer to the power source. The indication must be:
 - a) 120 volts ac for 2-wire 120 volt models.
 - b) 120 volts ac for 3-wire 120/208 and 120/240 volt models.
4. Disconnect the brewer from the power source.

If voltage is present as described, proceed to #5
 If voltage is not present as described, refer to *Wiring Diagram* and check brewer wiring harness.

5. Check for continuity across the solenoid valve coil terminals.

If continuity is present as described, reconnect the white/violet from the brew timer and white/green wire from the brew timer.

If continuity is not present as described, replace the solenoid valve.

6. Check the solenoid valve for coil action. Connect the brewer to the power source. With ON/OFF switch in the "ON" position press start switch and listen carefully in the vicinity of the solenoid valve for a "clicking" sound as the coil magnet attracts.
7. Disconnect the brewer from the power source.

If the sound is heard as described and water will not pass through the solenoid valve, there may be a blockage in the water line before the solenoid valve or, the solenoid valve may require inspection for wear, and removal of waterborne particles.

If the sound is not heard as described, replace the solenoid valve.

Removal and Replacement:

1. Remove all wires from solenoid valve.
2. Turn off the water supply to the brewer.
3. Disconnect the water lines to and from the solenoid valve.
4. Remove the two #10-32 slotted-head screws holding the solenoid valve to the bracket.
5. Securely install the new solenoid valve to the bracket.
6. Securely fasten the water lines to and from the solenoid valve.
7. Refer to the Fig. 5 when reconnecting the wires.

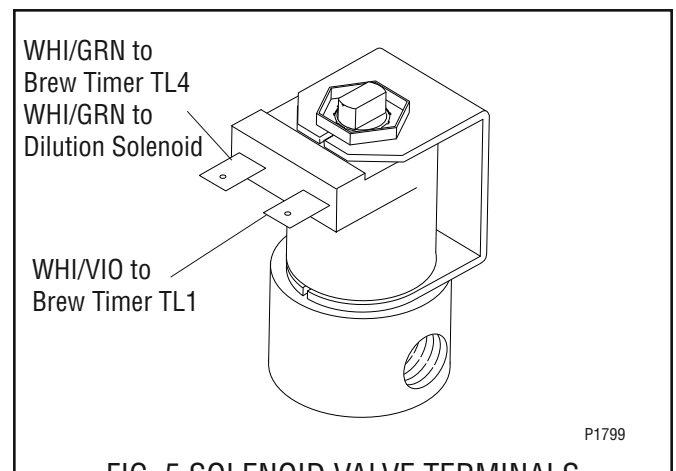
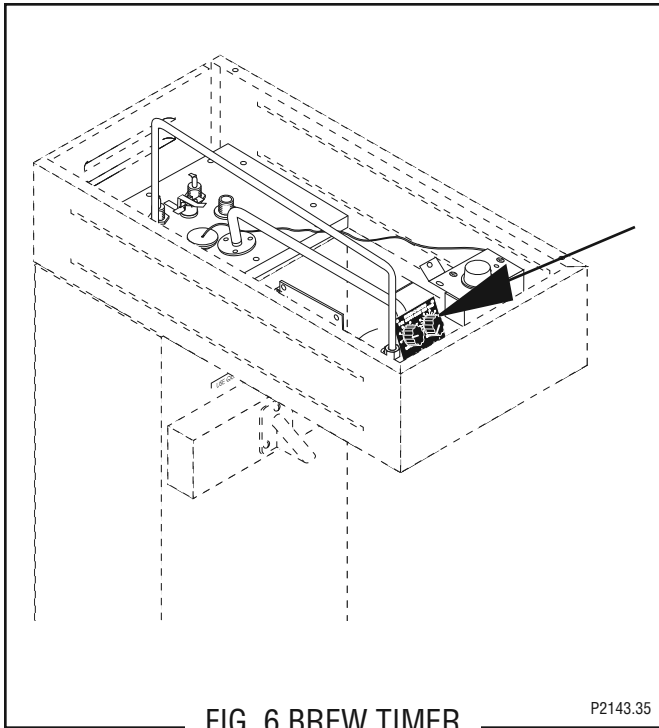

FIG. 5 SOLENOID VALVE TERMINALS

SERVICE (cont.)
BREW TIMER



Location:

The brew timer is located in the hood. It consists of the dial plate and circuit board.

Test Procedure:

1. Disconnect the brewer from the power source.
2. Remove the wires from terminals TL3, TL4, & TL5 of the timer and rotate the dials fully counterclockwise.
3. With a voltmeter, check the voltage across terminals TL1 and TL2 when the ON/OFF switch is in the "ON" position. Connect the brewer to the power source. The indication must be:
 - a) 120 volts ac for 2-wire 120 volt models.
 - b) 120 volts ac for 3-wire 120/208 and 120/240 volt models.
4. Disconnect the brewer from the power source.

If voltage is present as described, proceed to #5.
 If voltage is not present as described, refer to the Wiring Diagram and check the wiring harness.

5. Check for continuity across the white/orange and white/yellow wires when the start switch is held in the lower position.

If continuity is present as described, reconnect the wires to terminals TL3, TL4, & TL5 of the timer board and proceed to #6.

If continuity is not present as described, refer to the Wiring Diagram and check the wiring harness.

6. With a voltmeter, check the voltage across terminals TL1 and TL4 when the ON/OFF switch is in the "ON" position and the start switch is momentarily placed in the lower position. Connect the brewer to the power source. The indication must be:
 - a) 120 volts ac for 2-wire 120 volt models for approximately twenty seconds and then return to its previous indication.
 - b) 120 volts ac for 3-wire 120/208 and 120/240 volt models for approximately twenty seconds and then return to its previous indication.
7. Disconnect the brewer from the power source.

If voltage is present as described, the timer is operating properly. Adjust the timer dials as required.
 If voltage is not present as described, replace the timer.

Removal and Replacement:

1. Remove all wires from the timer.
2. Remove the circuit board and dial plate from the brackets.
3. Install the new dial plate and circuit board to the brackets.
4. Refer to Fig. 7 when reconnecting the wires.
5. Adjust the timer dials as required.

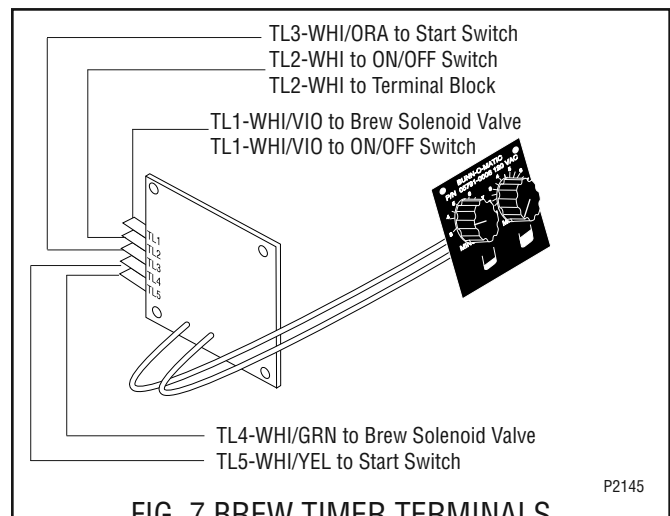

SERVICE (cont.)
CONTROL THERMOSTAT

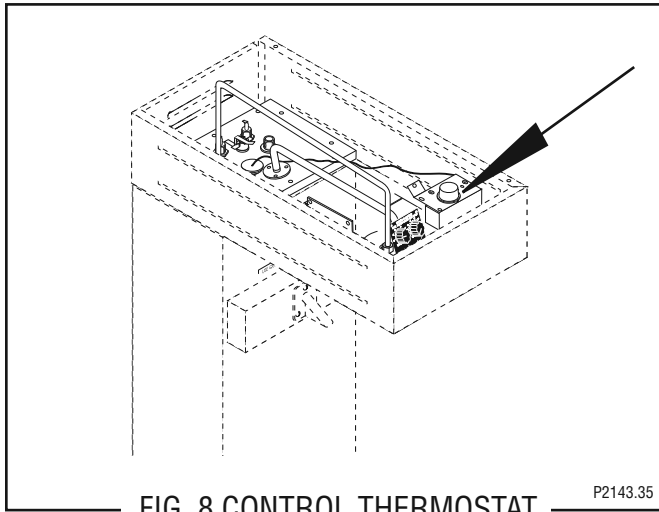

Location:

The control thermostat is located inside hood on the right side.

Test Procedures:

1. Disconnect the brewer from the power source.
2. Locate the blue/black wire on the control thermostat.
3. With a voltmeter, check the voltage across the blue wire on the control thermostat and the white or red wire on the tank heater. Connect the brewer to the power source. The indication must be:
 - a) 120 volts ac for 2-wire 120 volt models.
 - b) 208 volts ac for 3-wire 120/208 volt models.
 - c) 240 volts ac for 3-wire 120/240 volt models.
4. Disconnect the brewer from the power source.

If voltage is present as described, proceed to #5.
If voltage is not present as described, refer to the wiring diagrams and check the brewer wiring harness.

5. Locate the black wire on the control thermostat.
6. Gently remove the capillary bulb and grommet from the tank.
7. With a voltmeter, check the voltage across the black wire of the control thermostat and the white or red wire on the tank heater when the control thermostat is turned fully clockwise. Connect the brewer to the power source. The indication must be:

- a) 120 volts ac for 2-wire 120 volt models.
 - b) 208 volts ac for 3-wire 120/208 volt models.
 - c) 240 volts ac for 3-wire 120/240 volt models.
8. Disconnect the brewer from the power source.

If voltage is present as described, reinstall the capillary tube into the tank to the line 5.5" above the bulb, the control thermostat is operating properly.

If voltage is not present as described, replace the thermostat.

Removal and Replacement:

1. Remove both wires from the control thermostat terminals.
2. Remove the thermostat capillary bulb by firmly pulling up on the capillary tube at the tank lid. This will disengage the grommet from the tank lid.
3. Remove the #8-32 screw holding the control thermostat to its bracket.
4. Slide the grommet to the line 5.5" above the bulb on the new capillary tube.
5. Insert the capillary bulb through the hole in the tank lid and press the grommet firmly and evenly so that the groove in the grommet fits into the tank lid.
6. Carefully bend the capillary tube so that the tube and bulb inside the tank are in a vertical position.

NOTE – The capillary tube must be clear of any electrical termination and not kinked.

7. Fasten the new control thermostat to its bracket.
8. Refer to Fig. 9 when reconnecting the wires.
9. Adjust the control thermostat as required.

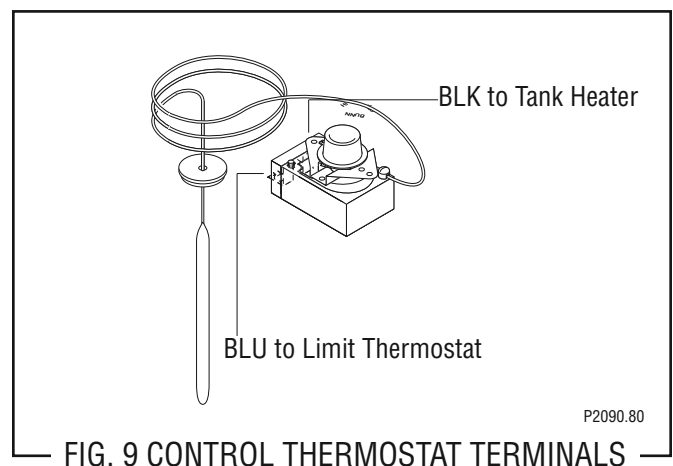

SERVICE (cont.)

DILUTION SOLENOID VALVE

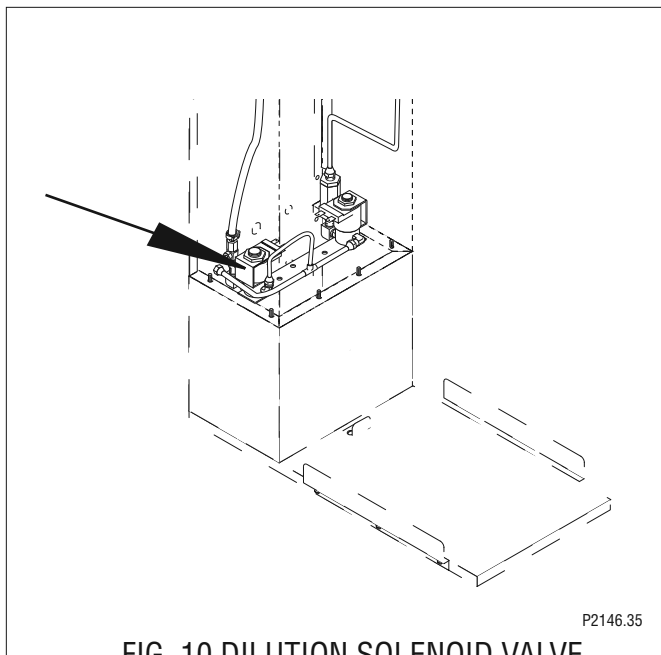

FIG. 10 DILUTION SOLENOID VALVE

Location:

The dilution solenoid valve is located behind the upper rear access panel on the right side of the bracket, when looking at it from the rear of the brewer.

Test Procedures:

1. Disconnect the brewer from the power source.
2. Place Dilution switch in "DILUTION" position.
3. Disconnect the white/blue and white/green wires from the solenoid valve. With the ON/OFF switch in the "ON" position press the start switch.
4. With a voltmeter, check the voltage across the white/blue and white/green wires. Connect the brewer to the power source. The indication must be:
 - a) 120 volts ac for 2-wire 120 volt models.
 - b) 120 volts ac for 3-wire 120/208 and 120/240 volt models.
4. Disconnect the brewer from the power source.

If voltage is present as described, proceed to #5. If voltage is not present as described, refer to *Wiring Diagram* and check brewer wiring harness.

5. Check for continuity across the solenoid valve coil terminals.

If continuity is present as described, reconnect the white/blue wire from the dilution switch and white/green wire from the brew solenoid terminal. If continuity is not present as described, replace the solenoid valve.

6. Check the solenoid valve for coil action. Connect the brewer to the power source. With ON/OFF switch in the "ON" position press start switch and listen carefully in the vicinity of the solenoid valve for a "clicking" sound as the coil magnet attracts.
7. Disconnect the brewer from the power source.

If the sound is heard as described and water will not pass through the solenoid valve, there may be a blockage in the water line before the solenoid valve or, the solenoid valve may require inspection for wear, and removal of waterborne particles. If the sound is not heard as described, replace the solenoid valve.

Removal and Replacement:

1. Remove all wires from solenoid valve.
2. Turn off the water supply to the brewer.
3. Disconnect the water lines to and from the solenoid valve.
4. Remove the two #10-32 slotted-head screws holding the solenoid valve to the bracket.
5. Securely install the new solenoid valve to the bracket.
6. Securely fasten the water lines to and from the solenoid valve.
7. Refer to FIG. 11 when reconnecting the wires.

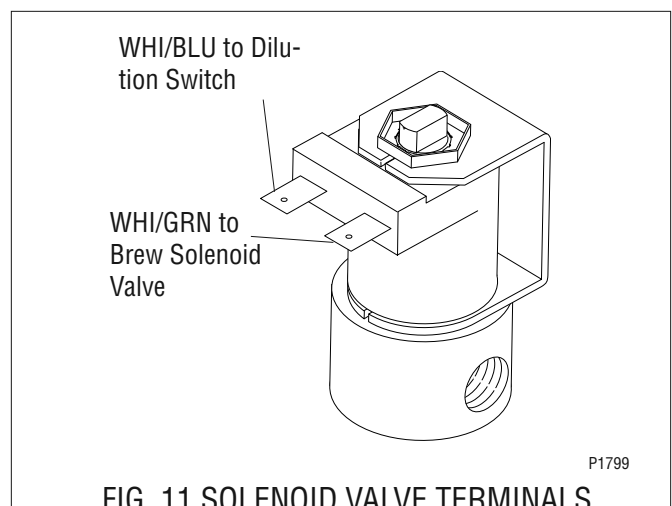

FIG. 11 SOLENOID VALVE TERMINALS

SERVICE (cont.)

DILUTION SWITCH

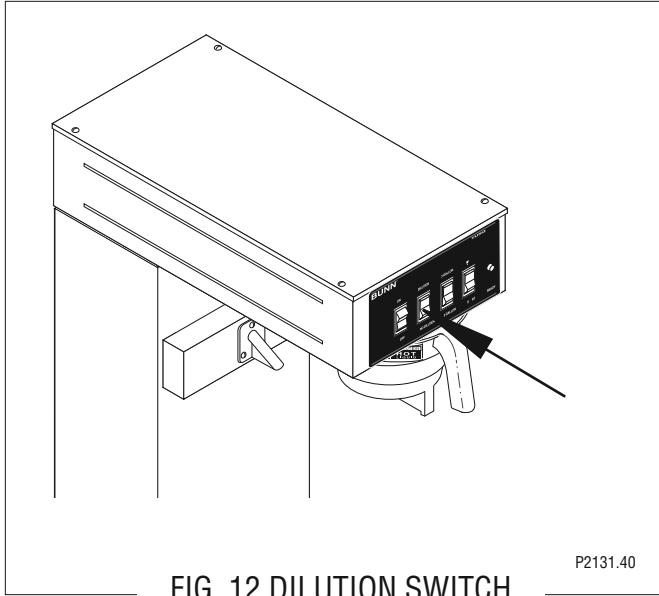

FIG. 12 DILUTION SWITCH

Location:

The dilution switch is located in the front of the hood, above and to the left of the brew funnel, and right of the ON/OFF switch. It is the second switch from the left.

Test Procedures:

1. Disconnect the brewer from the power source.
2. Remove the wires from all terminals.
3. Set Dilution switch to "DILUTION".
4. Check for continuity between the terminals where the white/blue and white/violet wires connect to the switch. Continuity should be present.

If continuity is present as described, reconnect the wires. The switch is operating properly. If continuity is not present as described, replace the switch.

5. Set Dilution switch to "NO DILUTION".
6. Check for continuity between the terminals where the white/blue and white/violet connect to the switch. Continuity should not be present.

If continuity is present as described, reconnect the wires. The switch is operating properly. If continuity is not present as described, replace the switch.

Removal and Replacement:

1. Remove the wires from the switch terminals.
2. Compress the clips inside the hood and gently push the switch through the opening.
3. Push the new switch into the opening and spread the clips to hold the switch captive in the hood.
4. Refer to Fig. 13 when reconnecting the wires.

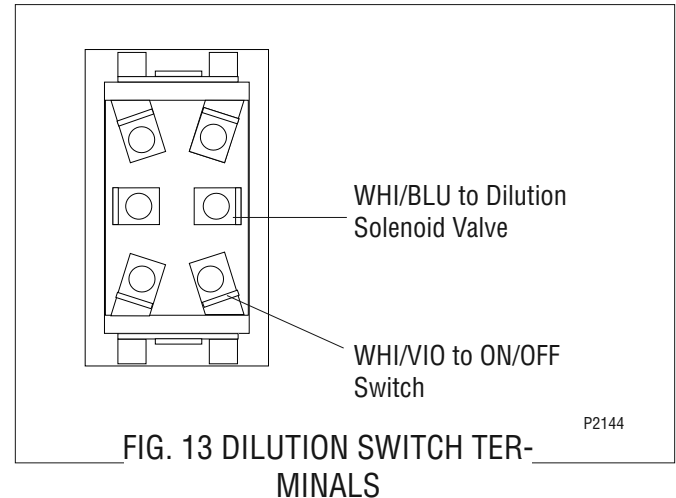

FIG. 13 DILUTION SWITCH TERMINALS

SERVICE (cont.)

LIMIT THERMOSTAT

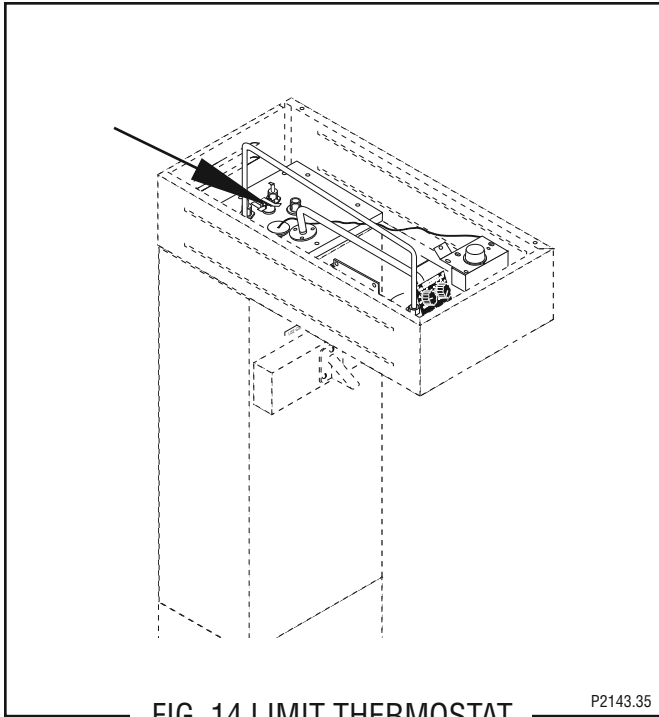

FIG. 14 LIMIT THERMOSTAT

Location:

The limit thermostat is located inside the hood on the tank lid.

Test Procedure:

1. Disconnect the brewer from the power source and remove the black wire from the limit thermostat.
2. With a voltmeter, check the voltage across the black wire removed from the limit thermostat and the white or red wire on the tank heater terminal. Connect the brewer to the power source. The indication must be:
 - a) 120 volts ac for 2-wire 120 volt models.
 - b) 208 volts ac for 3-wire 120/208 volt models.
 - c) 240 volts ac for 3-wire 120/240 volt models.
3. Disconnect the brewer from the power source.

If voltage is present as described, reconnect the black wire and proceed to #4.

If voltage is not present as described, refer to the Wiring Diagrams and check the wiring harness.

4. Remove the blue wire from the limit thermostat.
5. With a voltmeter, check the voltage across the exposed terminal of the limit thermostat and the

white or red wire on the tank heater terminal. Connect the brewer to the power source. The indication must be:

- a) 120 volts ac for 2-wire 120 volt models.
 - b) 208 volts ac for 3-wire 120/208 volt models.
 - c) 240 volts ac for 3-wire 120/240 volt models.
6. Disconnect the brewer from the power source.

If voltage is present as described, reconnect the blue wire to the limit thermostat. The limit thermostat is operating properly.

If voltage is not present as described, replace the limit thermostat.

Removal and Replacement

1. Remove both wires from the limit thermostat terminals.
2. Carefully slide the limit thermostat out from under the retaining clip.
3. Carefully slide the new limit thermostat into the retaining clip.
4. Refer to Fig. 15 when reconnecting the wires.

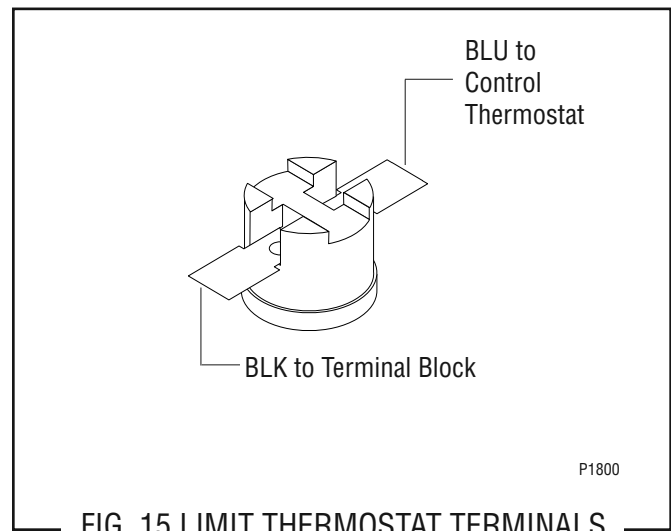

FIG. 15 LIMIT THERMOSTAT TERMINALS

SERVICE (cont.)
ON/OFF SWITCH

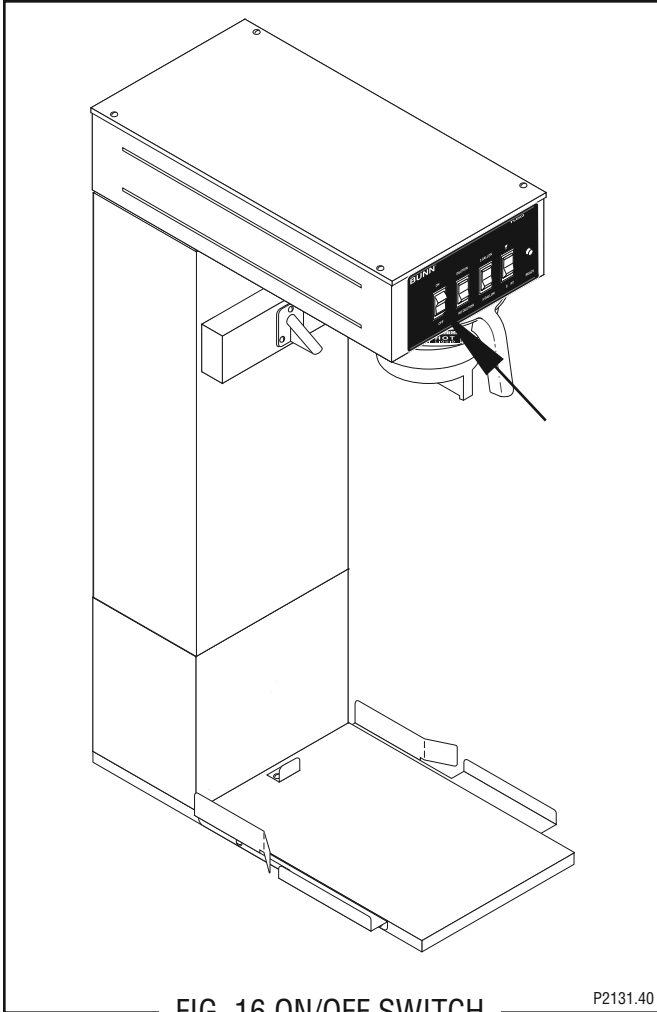

FIG. 16 ON/OFF SWITCH P2131.40

Location:

The ON/OFF switch is located in the front of the hood, above and to the left of the brew funnel.

Test Procedure:

1. Disconnect the brewer from the power source.
2. Remove the black and white/violet wires from the switch terminals.
3. With a voltmeter, check the voltage across the black wire removed from the ON/OFF switch and the white wire on the switch terminal.
4. Connect the brewer to the power source. The indication must be:
 - a) 120 volts ac for 2-wire 120 volt models.
 - b) 120 volts ac for 3-wire 120/208 and 120/240 volt models.

5. Disconnect the brewer from the power source.

If voltage is present as described, proceed to #6. If voltage is not present as described, refer to the Wiring Diagrams and check the wiring harness.

6. Check for continuity across the center and end terminals of the bottom row when the switch is in the "ON" position.

If continuity is present as described, replace the wires, the switch is operating properly.

If continuity is not present as described, replace the switch.

Removal and Replacement:

1. Remove the wires from the switch terminals.
2. Compress the clips inside the hood and gently push the switch through the opening.
3. Push the new switch into the opening and spread the clips to hold the switch captive in the hood.
4. Refer to FIG. 17 when reconnecting the wires.

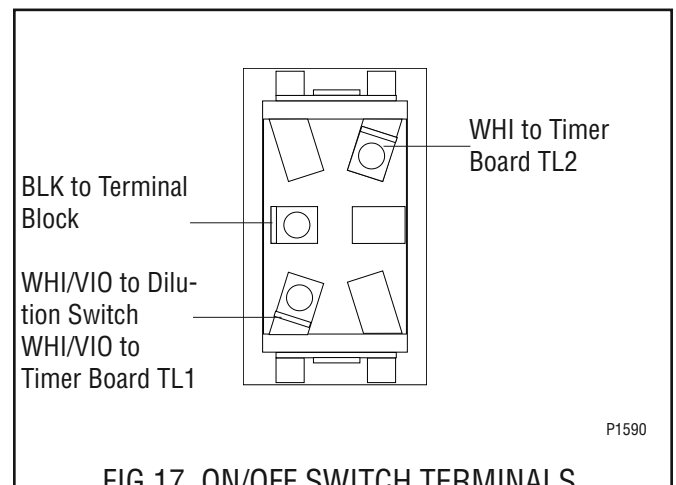
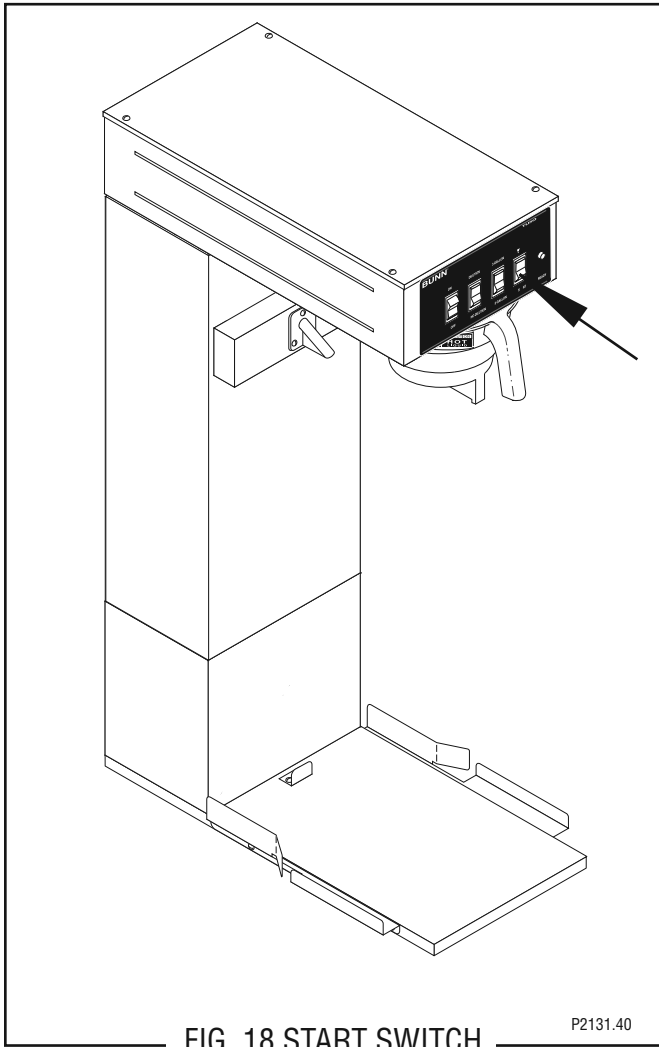

FIG. 17 ON/OFF SWITCH TERMINALS P1590

SERVICE (cont.)

START SWITCH



Location:

The start switch is located in the front of the hood, above and to the right of the brew funnel.

Test Procedure:

1. Disconnect the brewer from the power source.
2. Remove the wires from all terminals.
3. Check for continuity across the two terminals on the right side of the switch when it is held in the lower position. Continuity must not be present across these terminals in the upper position.

If continuity is present as described, reconnect the wires, the switch is operating properly.
If continuity is not present as described, replace the switch.

Removal and Replacement:

1. Remove the wires from the switch terminals.
2. Compress the clips inside the hood and gently push the switch through the opening.
3. Push the new switch into the opening and spread the clips to hold the switch captive in the hood.
4. Refer to Fig. 19 when reconnecting the wires.

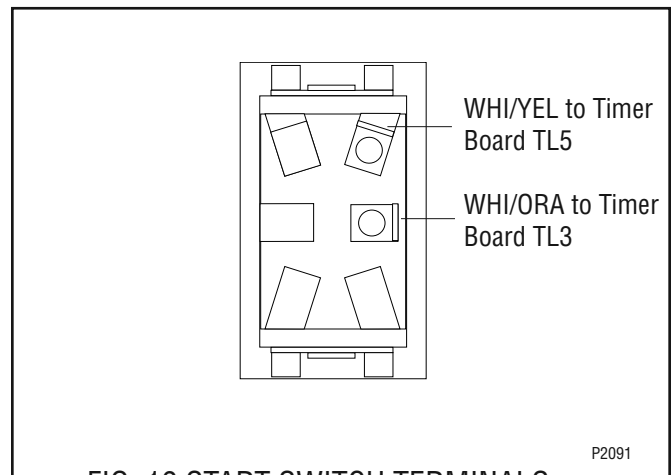

SERVICE (cont.)

TANK HEATER

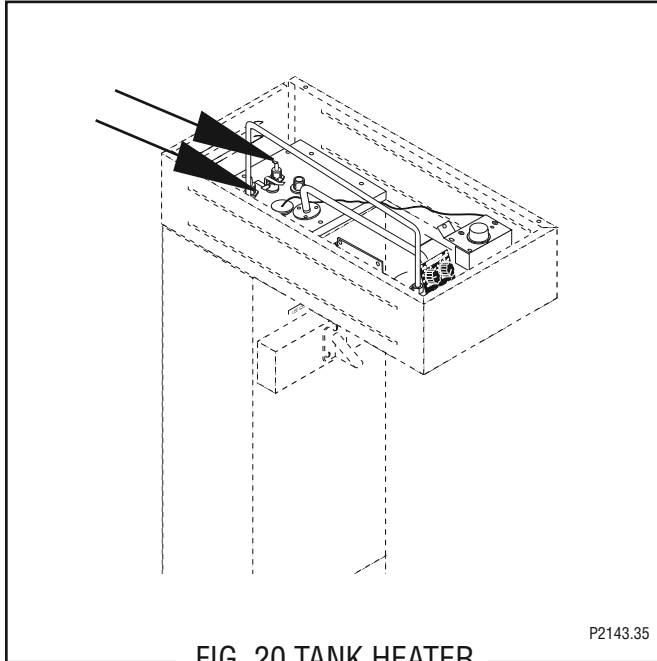

Location:

The tank heater is located inside the tank and secured to the tank lid.

Test Procedures:

1. Disconnect the brewer from the power supply.
2. With a voltmeter, check the voltage across the black and white or red wires. Connect the brewer to the power source. The indication must be:
 - a) 120 volts ac for 2-wire 120 volt models.
 - b) 208 volts ac for 3-wire 120/208 volt models.
 - c) 240 volts ac for 3-wire 120/240 volt models.
3. Disconnect the brewer from the power source.

If voltage is present as described, proceed to #4
If voltage is not present as described, refer to the *Wiring Diagram* and check wiring harness.

4. Disconnect the black wire and the white or red wire from the tank heater terminals.
5. Check for continuity across the tank heater terminals.

If continuity is present as described, reconnect the wires, the tank heater is operating properly.

If continuity is not present as described, replace the tank heater.

NOTE- If the tank heater remains unable to heat, remove and inspect heater for cracks in the sheath.

Removal and Replacement:

1. Disconnect the black wire and the white or red wire from the tank heater terminals.
2. Remove sprayhead and the hex nut securing the sprayhead tube to the hood. Set aside for reassembly.
3. Disconnect vent tube and water inlet tube.
4. Remove the eight #8 keps nuts securing the tank lid to the tank.
5. Remove the tank lid with limit thermostat, sprayhead tube, tank heater and vent tube.
6. Remove the two hex nuts securing the tank heater to the tank lid. Remove tank heater with gaskets and discard.
7. Install new tank heater with gaskets on the tank lid and secure with two hex nuts.
8. Install tank lid with limit thermostat, sprayhead tube, tank heater and vent tube using eight #8 keps nuts.
9. Secure sprayhead tube to hood using a hex nut.
10. Install sprayhead.
11. Connect vent tube and water inlet tube to fitting.
12. Reconnect the wires to the limit thermostat and tank heater. See limit thermostat section in this manual when reconnecting wires.
13. Refer to Fig. 21 when reconnecting the tank heater wires.

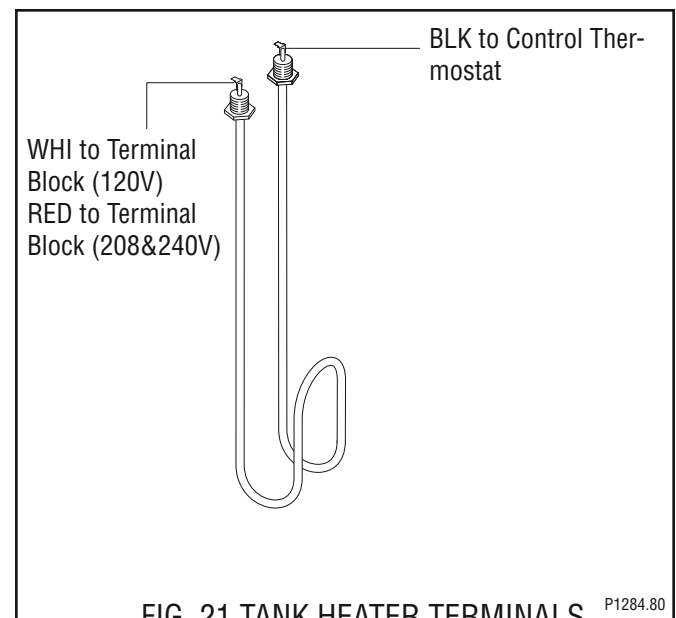

SCHEMATIC WIRING DIAGRAM TU5Q

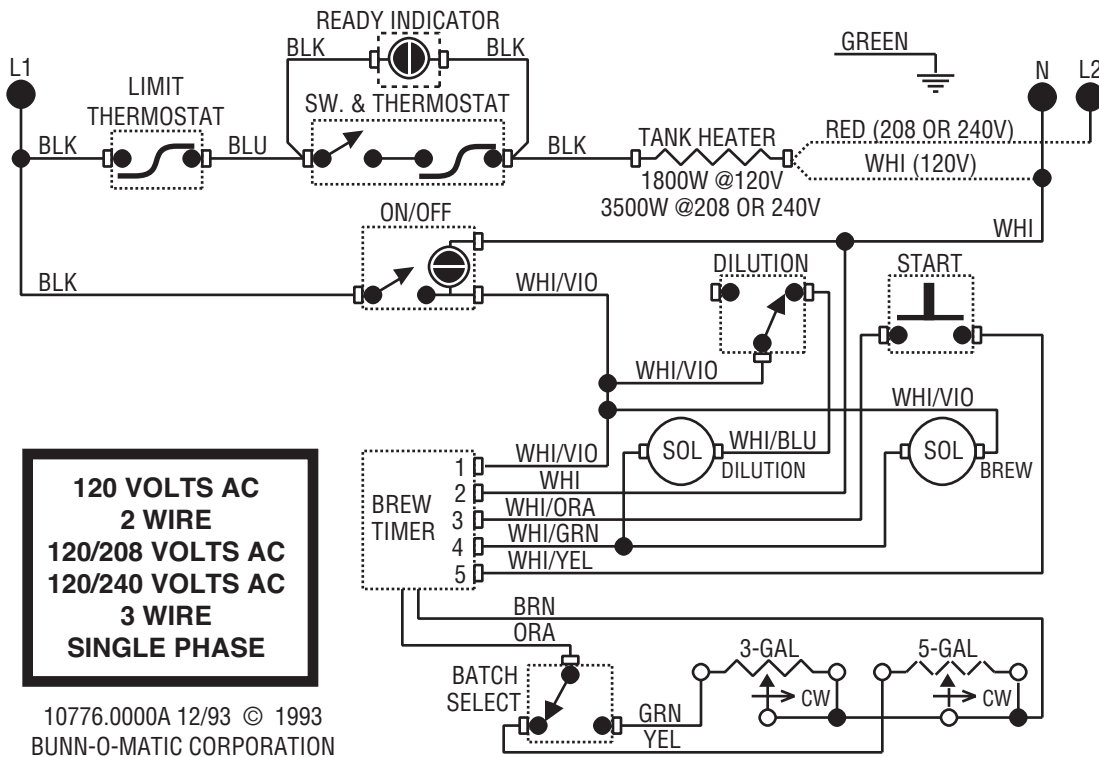

SCHEMATIC WIRING DIAGRAM TU5Q W/SWEETENER

