

**IC2 & IC2B**  
ICED COFFEE BREWERS

---

## **INSTALLATION & OPERATING INSTRUCTIONS**

---

### **INTRODUCTION**

This equipment will brew a batch of fresh coffee into an awaiting vessel and dispense at approximately room temperature to conserve ice. The brewer is only for indoor use on a sturdy counter or shelf and requires a minimum of 32 inches of clearance above the counter.

### **WARRANTY**

Bunn-O-Matic Corp. ("Bunn") warrants the equipment manufactured by it to be commercially free from defects in material and workmanship existing at the time of manufacture and appearing within one year from the date of installation. This warranty does not apply to any equipment, component or part that was not manufactured by Bunn or that, in Bunn's judgement, has been affected by misuse, neglect, alteration, improper installation or operation, improper maintenance or repair, damage or casualty.

**DISCONTINUED VERSION**

**The information in this manual  
is no longer current.**

OR  
IER  
unn  
| on  
and

529-6601 or by writing to Post Office Box 3227, Springfield, Illinois, 62708-3227. If requested by Bunn, the Buyer shall ship the defective equipment prepaid to an authorized Bunn service location. If Bunn determines, in its sole discretion, that the equipment does not conform to the warranty, Bunn shall repair the equipment with no charge for parts during the one year warranty period and no charge for labor by a Bunn Authorized Service Representative during the one year warranty period. If Bunn determines that repair is not feasible, Bunn shall, at its sole option, replace the equipment or refund the purchase price for the equipment.

**THE BUYER'S REMEDY AGAINST BUNN FOR THE BREACH OF ANY OBLIGATION ARISING OUT OF THE SALE OF THIS EQUIPMENT, WHETHER DERIVED FROM WARRANTY OR OTHERWISE, SHALL BE LIMITED, AS SPECIFIED HEREIN, TO REPAIR OR, AT BUNN'S SOLE OPTION, REPLACEMENT OR REFUND.** Bunn shall not be liable for any other damage or loss, including, but not limited to, lost profits, lost sales, loss of use of equipment, claims of Buyer's customers, cost of capital, cost of down time, cost of substitute equipment, facilities or services, or any other special, incidental or consequential damages.

---

**BUNN-O-MATIC CORPORATION**

POST OFFICE BOX 3227

SPRINGFIELD, ILLINOIS 62708-3227

PHONE: (217) 529-6601 FAX: (217) 529-6644

## USER NOTICES

The notices on this brewer should be kept in good condition. Replace unreadable or damaged labels.



03408.0000

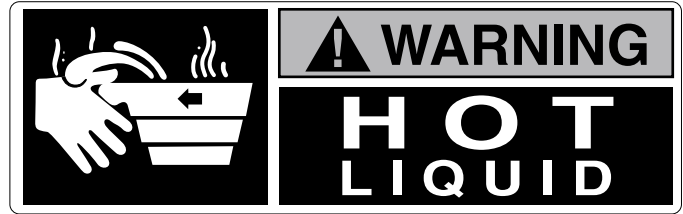

03409.0000

<b>⚠ WARNING</b>	
◆	Fill water tank before turning -on thermostat or connecting appliance to power source.
◆	Use only on a properly protected circuit capable of the rated load.
◆	Electrically ground the chassis.
◆	Follow national/local electrical codes.
◆	Do not use near combustibles.
FAILURE TO COMPLY RISKS EQUIPMENT DAMAGE, FIRE, OR SHOCK HAZARD	
READ THE ENTIRE OPERATING MANUAL BEFORE BUYING OR USING THIS PRODUCT	
THIS APPLIANCE IS HEATED WHENEVER CONNECTED TO A POWER SOURCE	
00831.0000F 3/98 © 1988 BUNN-O-MATIC CORPORATION	

00831.0000

## ELECTRICAL REQUIREMENTS

**CAUTION** - Do not connect the brewer to the power source until specified in Initial Set-Up.

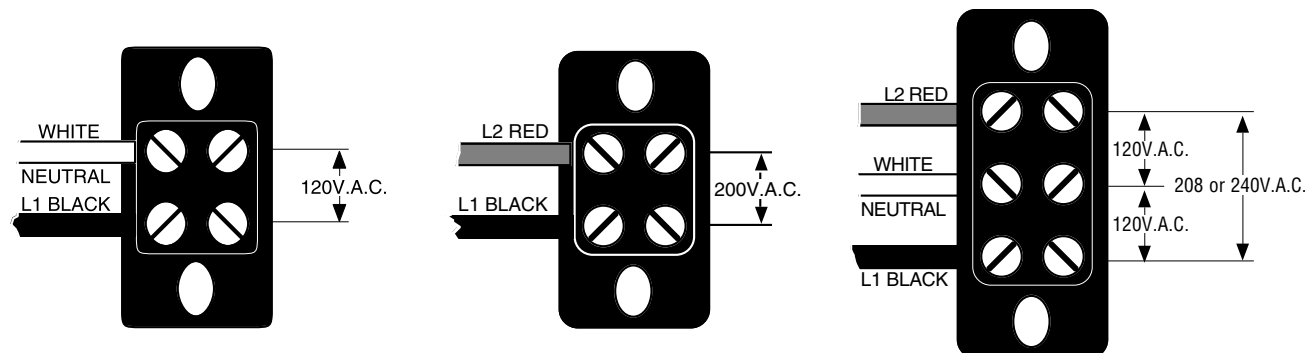

These brewers require 2-wire, grounded service rated 120 or 200 volts ac or 3-wire, grounded service rated 120/208 or 120/240 volts ac, 20 amp, single phase, 60 Hz. Refer to the product's data plate above the dilution nozzle for actual voltage of your particular brewer model.

## Electrical Hook-Up

**CAUTION** – Improper electrical installation will damage electronic components.

1. An electrician must provide electrical service as specified.
2. Remove the top lid and rotate the control thermostat knob fully counterclockwise to the “OFF” position and reinstall the top lid.
3. Remove the rear trunk panel, feed the cord through the strain relief at the rear of the brewer and connect it to the terminal block.
4. Using a voltmeter, check the voltage and color coding of each conductor at the power source.
5. Connect the brewer to the power source and verify the voltage at the terminal block and reinstall the rear trunk panel.
6. If plumbing is to be hooked-up later be sure the brewer is disconnected from the power source. If plumbing has been hooked-up, the brewer is ready for Initial Set-Up.

**WARNING** – The brewer must be electrically grounded using the green screw near the terminal block. Do not assume a plumbing line will provide an adequate ground.

## PLUMBING REQUIREMENTS

This brewer must be connected to a cold water system with operating pressure between 30 and 90 psi (207 and 620 kPa) from a ½" or larger supply line. A shut-off valve should be installed in the line before the brewer. Install a regulator in the line when pressure is greater than 90 psi (620 kPa) to reduce it to 50 psi (345 kPa). The water inlet fitting is ¼" flare.

**NOTE** - Bunn-O-Matic recommends ¼" copper tubing for installations of less than 25 feet and ⅜" for more than 25 feet from the ½" water supply line. A tight coil of copper tubing in the water line will facilitate moving the brewer to clean the countertop. Bunn-O-Matic does not recommend the use of a saddle valve to install the brewer. The size and shape of the hole made in the supply line by this type of device may restrict water flow.

This equipment must be installed to comply with the Basic Plumbing Code of the Building Officials and Code Administrators International, Inc. (BOCA) and the Food Service Sanitation Manual of the Food and Drug Administration (FDA).

## Plumbing Hook-Up

1. Attach the female fitting from the short piece of tubing on the strainer assembly (supplied) to the water inlet fitting on the rear of the brewer.
2. Flush the water line and securely attach it to the flare fitting on the strainer assembly.
3. Turn on the water supply.

## INITIAL SET-UP

**CAUTION** - The brewer must be disconnected from the power source throughout the initial set-up, except when specified in the instructions.

1. Remove the top lid from the brewer.
2. Rotate the control thermostat knob fully counterclockwise to the “OFF” position. Set the timer knob at eight minutes and replace the top lid.
3. Insert an empty funnel into the funnel rails.
4. Place an empty two-gallon dispenser on the brewer base. The opening in the top of the dispenser must be directly beneath the funnel dripout and the dilution nozzle.

## **INITIAL SET-UP (cont.)**

5. Connect the brewer to the power source. Place the On/Off switch in the lighted “ON” position, the batch selector in the “FULL” position, and momentarily press the start switch. Water will flow into the tank for approximately eight minutes.
6. Press the start switch again to initiate a second cycle. During the second cycle, the tank will fill to its capacity and the excess will flow from the funnel into the dispenser. Empty the dispenser when the flow of water from the funnel stops.
7. Disconnect the brewer from the power source, remove the rear trunk panel, and turn the handle on the needle valve approximately one-quarter turn counterclockwise to enable the flow of dilution water. This valve is fully closed at the factory.

**NOTE** - The next step requires the use of a stopwatch to calculate the amount of dilution water flowing from the nozzle in one minute. You’ll need to capture and measure the timed dilution water in a separate vessel than the one used for the water flowing from the funnel.

8. Connect the brewer to the power source. Simultaneously press the start switch to begin another brew cycle and start the stop watch. Place the ON/OFF switch in the “OFF” position at exactly sixty-seconds (one-minute). When the flow of water stops, measure the volume of the captured dilution water. It should be approximately fifteen ounces.
9. If not, disconnect the brewer from the power source, and adjust the handle on the needle valve clockwise to decrease the amount of water or counterclockwise to increase the amount of dilution water as required.
10. Repeat steps 8 & 9 until the recommended dilution water volume (fifteen ounces) is achieved.
11. Disconnect the brewer from the power source and reinstall the rear trunk panel.
12. Remove the top lid, set the timer dial at the recommended setting, rotate the control thermostat knob fully clockwise to the “ON” position and replace the top lid.
13. Connect the brewer to the power source and wait for the ready light to glow indicating the water in the tank has heated to brewing temperature (approximately 20 minutes). Some water will drip from the funnel during this time; this is due to expansion and should not occur thereafter.
14. Begin another brew cycle. Empty the reservoir after water has stopped flowing from the funnel.
15. Allow the water in the tank to heat to the proper temperature.
16. Place an empty two-gallon dispenser on the brewer base and begin another brew cycle. At the completion of this cycle, carefully measure the total water in the dispenser. It should be as recommended.
17. If not, disconnect the brewer from the power source, remove the top lid, adjust the timer dial up or down as required, and replace the top lid.
18. Repeat steps 15 - 17 until the proper total water volume is achieved.
19. The brewer is now ready to brew a batch of freshly brewed room temperature coffee.

## **CLEANING**

**CAUTION** - Clean and sanitize your iced coffee brewer **daily**

1. Remove and thoroughly clean the entire brew funnel. The funnel must be free from any coffee particles or residue.
2. Disconnect the brewer from the power source. Remove and thoroughly rinse the sprayhead. Wipe the sprayhead panel clean with a damp cloth.
3. Insert the delimiting spring into the sprayhead fitting until no more than one inch is visible and move it in and out 5 or 6 times. Insert the spring into the airvent hole in the sprayhead panel and move it in and out 5 or 6 times. Reattach the sprayhead.
4. Wash the entire outside surface of the brewer with a clean damp cloth.

**CAUTION** - Do not keep brewed coffee overnight. The dispenser must be cleaned and sanitized daily.

## **OPERATING CONTROLS**

### **A. Lighted On/Off Switch**

**ON** - Placing the switch in the lighted upper position allows the start switch to activate a brew cycle.

**OFF** - Placing the switch in the lower position stops the brew cycle. Stopping a brew cycle after it has been started will not stop the flow of water into the funnel until the tank syphons down to its proper level.

**NOTE** - The switch should always be placed in the "OFF" position after a brew cycle and whenever the brewer is unattended.

### **B. Start Switch**

Starts a brew cycle when the lighted On/Off switch is in the "ON" position.

## **COFFEE BREWING**

1. Begin each brew cycle with a clean empty brew funnel and dispenser. (Be sure the dispenser lid doesn't interfere with the flow of dilution water.)
  2. Insert a BUNN® tea filter into the funnel.
  3. Pour the recommended amount of fresh coffee into the filter.
  4. Level the bed of coffee grounds by gently shaking.
  5. Slide the funnel into the funnel rails until it stops.
  6. Place the On/Off switch in the lighted "ON" position.
  7. Place the batch selector switch in the desired position.
  8. Momentarily press the start switch.
- CAUTION** - The funnel contains hot liquids. Remove funnel slowly.
9. Carefully remove the funnel and discard the used filter when coffee no longer drips from the funnel.
  10. Place the lighted On/Off switch in the "OFF" position to prevent a false start.
  11. Room temperature fresh coffee is available at the faucet.

## REPLACEMENT PARTS

03772.0000 .... Base Guide  
00603.0000 .... Cable Clamp .437"  
03024.0005 .... Control Thermostat  
03409.0000 .... Decal, Caution, Hot Liquid  
03408.0000 .... Decal, Caution, Remove Funnel Slowly  
24739.0000 .... Decal, Hood Front  
03717.0000 .... Dilution Nozzle  
03773.0000 .... Dilution Nozzle Spacer Housing  
00459.0001 .... Fitting, Bulkhead, .25" Male Flare  
00400.0001 .... Fitting, Elbow, .25" Male Flare x .125" MPT  
00412.0001 .... Fitting, Hex Nipple, .125" MPT  
00430.0001 .... Fitting, Adapter .125" NPT Male-Female  
00469.0001 .... Fitting, Connector .25" Barb x .125" FPT  
00432.0001 .... Fitting, Street Elbow, .125" NPT  
24599.0001 .... Fitting, Tee Union, .125" FPT  
20528.1222 .... Flow Control Assy, .22 gpm  
01155.0000 .... Flow Control Gasket  
01154.0001 .... Flow Control Outlet  
20526.0222 .... Flow Control Washer, .22 gpm  
24600.0000 .... Foot Replacement Kit  
12485.0004 .... Funnel Handle  
24659.0001 .... Funnel Handle Mounting Bracket  
12499.0000 .... Funnel Handle Screw  
24790.0000 .... Funnel Assy, Complete  
20201.4150 .... Heater Kit, 1800W/120V  
20201.6350 .... Heater Kit, 3500W/208V - 3235W/200V  
20201.0750 .... Heater Kit, 3500W/240V  
00668.0000 .... Hole Plug, .75" Dia  
12422.0000 .... Hose Clamp .5"  
04680.0000 .... Limit Thermostat (120V)  
04680.0002 .... Limit Thermostat (208/240V)  
03170.0000 .... Mounting Plate, Solenoid Valve  
21634.0003 .... Needle Valve  
12984.0002 .... Ready Indicator Assy, Green (120V)  
12984.0004 .... Ready Indicator Assy, Green (200/240V)  
10967.0000 .... Shipping Carton Complete  
01592.0000 .... Snap Bushing 1" Dia  
01079.0000 .... Solenoid Valve Base  
01101.0000 .... Solenoid Valve Coil (120V)  
21181.0000 .... Solenoid Valve Coil (200V)  
01111.0000 .... Solenoid Valve Repair Kit  
01085.0000 .... Solenoid Valve (120V)  
21180.0000 .... Solenoid Valve (200V)  
01082.0002 .... Sprayhead Assy  
05515.0000 .... Sprayhead Tube Gasket  
24808.0000 .... Sprayhead Tube Kit  
02753.0000 .... Switch, Lighted On/Off (120V)  
02754.0000 .... Switch, Lighted On/Off (200/240V)  
02628.0000 .... Switch, Momentary Start  
24549.0000 .... Tank  
23199.0000 .... Tank Lid  
22978.0000 .... Tank Lid Gasket  
07038.0000 .... Terminal Block (120/208 - 120/240V)  
01106.0000 .... Terminal Block (120V)  
01106.0001 .... Terminal Block (200V)  
02620.1003 .... Timer, 5 Min (120V)  
02620.1043 .... Timer, 5 Min (200/240V)  
24481.0000 .... Top Lid  
24802.0000 .... Trunk Rear Panel W/Decals  
24787.0000 .... Tube Assy, Bulkhead Fitting to Solenoid  
24786.0000 .... Tube Assy, Flow Control To Tank  
20202.0101 .... Tube Assy, Tank Fill  
24509.0000 .... Tube Assy, Vent  
00310.0002 .... Tube Assy, Water Strainer to Bulkhead Fitting  
11707.1001 .... Tube, Silicone .25" ID x 36"  
22249.0000 .... Water Strainer End Cap .25" Flare  
23721.0000 .... Water Strainer Replacement Screen  
23820.1000 .... Water strainer Assy, Complete  
01069.0003 .... Wire Assy, Control Thermostat, Black  
01069.0004 .... Wire Assy, Control Thermostat, Blue  
24541.0000 .... Wire Assy, Thermostat to Limit  
24542.0000 .... Wire Assy, Thermostat to Tank Heater  
24758.0000 .... Wiring Harness, Main (120V)  
24758.0001 .... Wiring Harness, Main (120/208 -120/240V)  
24758.0002 .... Wiring Harness, Main (200V)

# SCHEMATIC WIRING DIAGRAM IC2

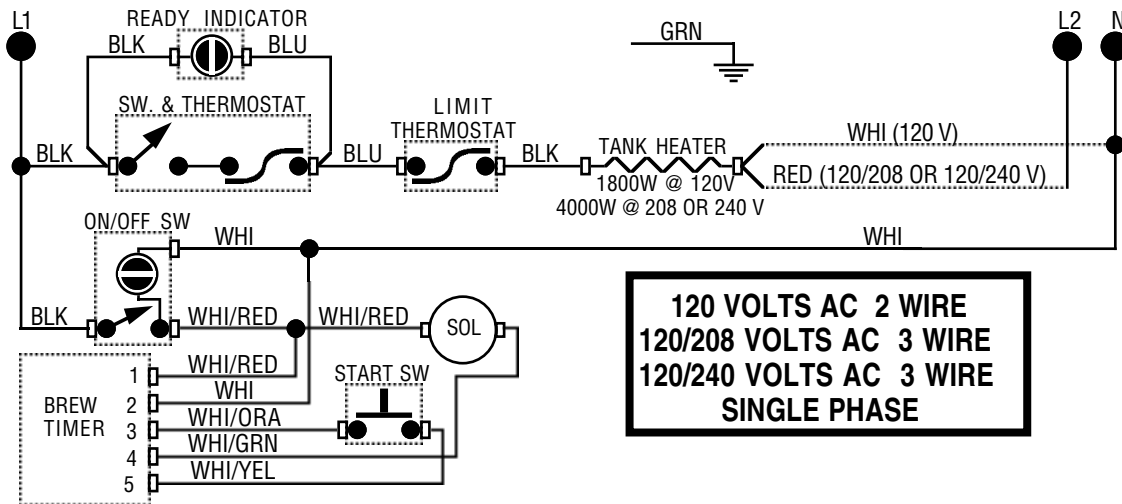

# SCHEMATIC WIRING DIAGRAM IC2B

