

BUNN®

TU3Q-EZ

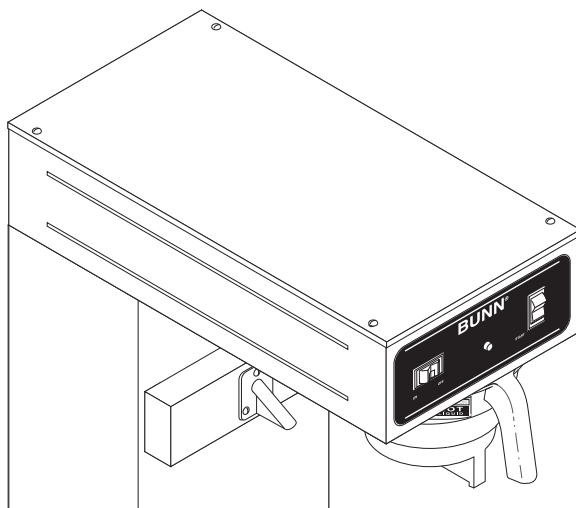

DISCONTINUED VERSION
The information in this manual
is no longer current.

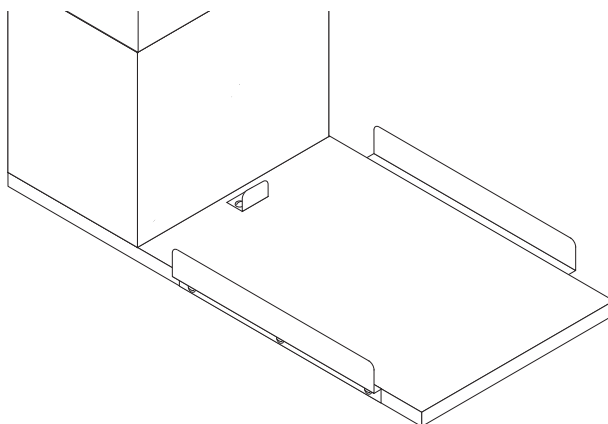

OPERATING & SERVICE MANUAL

BUNN-O-MATIC CORPORATION

POST OFFICE BOX 3227
SPRINGFIELD, ILLINOIS 62708-3227
TELEPHONE: (217) 529-6601 FAX: (217) 529-6644

CONTENTS

Introduction	2
Warranty	2
User Notices	3
Electrical Requirements	4
Plumbing Requirements	4
Initial Set-Up	5
Operating Controls	6
Cleaning	6
Tea Brewing	6
Adjustments and Optional Settings	7
Troubleshooting	8
Service	14
Wiring Schematic	22

INTRODUCTION

This equipment will brew a three-gallon batch of fresh tea into an awaiting dispenser. The tea will be dispensed at approximately room temperature to conserve ice. The brewer is only for indoor use on a sturdy counter or shelf.

WARRANTY

Bunn-O-Matic Corp. ("Bunn") warrants the equipment manufactured by it to be commercially free from defects in material and workmanship existing at the time of manufacture and appearing within one year from the date of installation. In addition:

1.) Bunn warrants electronic circuit and/or control boards to be commercially free from defects in material and workmanship for two years from the date of installation.

2.) Bunn warrants the compressor on refrigeration equipment to be commercially free from defects in material and workmanship for two years from the date of installation.

3.) Bunn warrants that the grinding burrs on coffee grinding equipment will grind coffee to meet original factory screen sieve analysis for three years from date of installation or for 30,000 pounds of coffee, whichever comes first.

This warranty does not apply to any equipment, component or part that was not manufactured by Bunn or that, in Bunn's judgement, has been affected by misuse, neglect, alteration, improper installation or operation, improper maintenance or repair, damage or casualty.

THE FOREGOING WARRANTY IS EXCLUSIVE AND IS IN LIEU OF ANY OTHER WARRANTY, WRITTEN OR ORAL, EXPRESS OR IMPLIED, INCLUDING, BUT NOT LIMITED TO, ANY IMPLIED WARRANTY OF EITHER MERCHANTABILITY OR FITNESS FOR A PARTICULAR PURPOSE. The agents, dealers or employees of Bunn are not authorized to make modifications to this warranty or to make additional warranties that are binding on Bunn. Accordingly, statements by such individuals, whether oral or written, do not constitute warranties and should not be relied upon.

The Buyer shall give Bunn prompt notice of any claim to be made under this warranty by telephone at (217) 529-6601 or by writing to Post Office Box 3227, Springfield, Illinois, 62708-3227. If requested by Bunn, the Buyer shall ship the defective equipment prepaid to an authorized Bunn service location. If Bunn determines, in its sole discretion, that the equipment does not conform to the warranty, Bunn shall repair the equipment with no charge for parts during the warranty period and no charge for labor by a Bunn Authorized Service Representative during the warranty period. If Bunn determines that repair is not feasible, Bunn shall, at its sole option, replace the equipment or refund the purchase price for the equipment.

THE BUYER'S REMEDY AGAINST BUNN FOR THE BREACH OF ANY OBLIGATION ARISING OUT OF THE SALE OF THIS EQUIPMENT, WHETHER DERIVED FROM WARRANTY OR OTHERWISE, SHALL BE LIMITED, AS SPECIFIED HEREIN, TO REPAIR OR, AT BUNN'S SOLE OPTION, REPLACEMENT OR REFUND.

In no event shall Bunn be liable for any other damage or loss, including, but not limited to, lost profits, lost sales, loss of use of equipment, claims of Buyer's customers, cost of capital, cost of down time, cost of substitute equipment, facilities or services, or any other special, incidental or consequential damages.

USER NOTICES

Carefully read and follow all notices on the equipment and in this manual. They were written for your protection. All notices on the equipment should be kept in good condition. Replace any unreadable or damaged labels.

#00831.0000

⚠ WARNING
<ul style="list-style-type: none"> ◆ Fill water tank before turning -on thermostat or connecting appliance to power source. ◆ Use only on a properly protected circuit capable of the rated load. ◆ Electrically ground the chassis. ◆ Follow national/local electrical codes. ◆ Do not use near combustibles.
FAILURE TO COMPLY RISKS EQUIPMENT DAMAGE, FIRE, OR SHOCK HAZARD
READ THE ENTIRE OPERATING MANUAL BEFORE BUYING OR USING THIS PRODUCT
THIS APPLIANCE IS HEATED WHENEVER CONNECTED TO A POWER SOURCE
<small>00831.0000F 3/98 © 1988 BUNN-O-MATIC CORPORATION</small>

#00656.0000

This equipment is to be installed to comply with the Basic Plumbing Code of the Building Officials and Code Administrators International, Inc. (BOCA) and the Food Service Sanitation Manual of the Food and Drug Administration (FDA).

#03408.0000

	<table border="1" style="width: 100%; border-collapse: collapse;"> <tr style="background-color: #cccccc;"> <td style="text-align: center; padding: 2px;">⚠ WARNING</td> </tr> <tr> <td style="text-align: center; padding: 5px;">REMOVE FUNNEL SLOWLY</td> </tr> </table>	⚠ WARNING	REMOVE FUNNEL SLOWLY
⚠ WARNING			
REMOVE FUNNEL SLOWLY			

#03409.0000

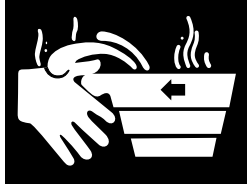
	<table border="1" style="width: 100%; border-collapse: collapse;"> <tr style="background-color: #cccccc;"> <td style="text-align: center; padding: 2px;">⚠ WARNING</td> </tr> <tr> <td style="text-align: center; padding: 5px;">HOT LIQUID</td> </tr> </table>	⚠ WARNING	HOT LIQUID
⚠ WARNING			
HOT LIQUID			

ELECTRICAL REQUIREMENTS

CAUTION - The brewer must be disconnected from the power source until specified in *Initial Set-Up*.

120V model brewers require 2-wire, grounded service rated 120 volts ac, 15 amp, single phase, 60 Hz. Proceed as follows:

Electrical Hook-Up

CAUTION – Improper electrical installation will damage electronic components.

1. An electrician must provide electrical service as specified.
2. Using a voltmeter, check the voltage at the electrical source.
3. Connect the brewer to the power source.
4. If plumbing is to be hooked up later be sure the brewer is disconnected from the power source. If plumbing has been hooked up, the brewer is ready for *Initial Set-Up*.

PLUMBING REQUIREMENTS

These brewers must be connected to a cold water system with operating pressure between 20 (138) and 90 psi (620 kPa) from a ½" or larger supply line. A shut-off valve should be installed in the line before the brewer. Install a regulator in the line when pressure is greater than 90 psi (620 kPa) to reduce it to 50 psi (345 kPa). The water inlet fitting is ¼" flare.

NOTE - Bunn-O-Matic recommends ¼" copper tubing for installations of less than 25 feet and ⅜" for more than 25 feet from the ½" water supply line. A tight coil of copper tubing in the water line will facilitate moving the brewer to clean the countertop. Bunn-O-Matic does not recommend the use of a saddle valve to install the brewer. The size and shape of the hole made in the supply line by this type of device may restrict water flow.

This equipment must be installed to comply with the Basic Plumbing Code of the Building Officials and Code Administrators International, Inc. (BOCA) and the Food Service Sanitation Manual of the Food and Drug Administration (FDA).

PLUMBING REQUIREMENTS (cont.)

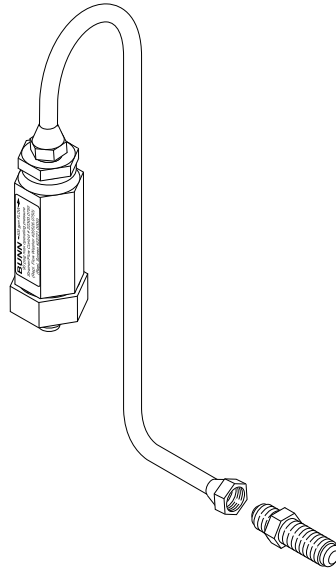

P1804

1. Remove the shipping cap from the bulkhead fitting on the rear of the brewer.
2. Attach the flare fitting from the short piece of tubing on the strainer/flow control (supplied) to the water inlet fitting at the rear of the brewer.
3. Flush the water line and securely attach it to the flare fitting on the strainer/flow control.
4. Turn on the water supply.

INITIAL SET-UP

CAUTION - The brewer must be disconnected from the power source throughout the initial set-up, except when specified in the instructions.

1. Insert an empty funnel into the funnel rails.
2. Place an empty container of at least 4 gal. capacity under the funnel.
3. Connect the brewer to the power source.
4. Place the "ON/OFF" switch in the "ON" position and momentarily press the "START" switch.
5. Water will flow into the tank and dispenser for approximately three and one-half minutes. Empty the dispenser when the first cycle stops and press the "START" switch again. Empty the dispenser when the second cycle stops and press the "START" switch once more. During the third cycle, the tank will fill to its capacity and the excess will flow from the brew funnel into the dispenser. Empty the dispenser when this third cycle stops.
6. Wait approximately twenty minutes for the water in the tank to heat to the proper temperature.
7. Place the "ON/OFF" switch in the "ON" position then momentarily press and release the "START" switch.
8. Allow the cycle to finish and measure the amount of water in the container. It should be 396 ounces \pm 2. Refer to *Adjustments & Optional Settings* to adjust the water volume, if needed..

The brewer is now ready for use in accordance with the *Tea Brewing* instructions.

OPERATING CONTROLS

A. ON/OFF Switch

ON - Placing the switch in the left position allows the start switch to activate a timed brew cycle for three gallons of tea.

OFF - Placing the switch in the right position stops the brew cycle. Stopping a brew cycle after it has been started will not stop the flow of water into the funnel until the tank syphons down to its proper level. **The switch should always be placed in this position after a brew cycle and whenever the brewer is unattended.**

B. Start Switch

Starts a brew cycle when the ON/OFF switch is in the "ON" position.

C. Ready Indicator

This indicator glows when preselected brew water temperature has been achieved. It is also used for diagnostic testing of brewer.

CLEANING

CAUTION - CLEAN AND SANITIZE YOUR ICED TEA BREWER DAILY

1. Remove and thoroughly clean the entire brew funnel. The funnel tip and screen must be free from any tea particles or residue. Reassemble the funnel.
2. Place the ON/OFF switch in the "OFF" position. Remove and thoroughly rinse the sprayhead. The holes must be open and clear of any mineral deposits. Wipe the sprayhead panel clean with a damp cloth.
3. Insert the delimiting spring into the sprayhead fitting until no more than two inches is visible and move it in and out 5 or 6 times. Reattach the sprayhead.
4. Wash the entire outside surface of the brewer with a clean damp cloth.

CAUTION - DO NOT KEEP BREWED ICED TEA OVERNIGHT. THE SERVER MUST BE CLEANED DAILY.

TEA BREWING

1. Begin each brew cycle with a clean empty brew funnel and server. (Be sure the server lid doesn't interfere with the flow of dilution water.)
2. Insert a BUNN® filter into the funnel.
3. Pour the packet of loose fresh tea leaves into the filter. Approximately four ounces is recommended.
4. Level the bed of tea leaves by gently shaking.
5. Slide the funnel into the funnel rails until it stops.
6. Place the ON/OFF switch in the "ON" position.
7. Momentarily press the start switch.

CAUTION - The funnel contains hot liquids. Remove funnel slowly.

8. Carefully remove the brew funnel and discard the used filter when tea no longer drips from the funnel tip.
9. Place the ON/OFF switch in the "OFF" position to prevent a false start.
10. Fresh tea is available at the faucet.

TU3Q-EZ ADJUSTMENTS & OPTIONAL SETTINGS

Setting Brew Lockout

The brew lockout feature prevents brewing when the brew water is 5° or more below the set temperature.

Place the shorting jumper across the LOCK set of pins to enable Brew Lockout.

Place the shorting jumper across the UNLOCK set of pins to disable Brew Lockout. (This allows brewing regardless of water temperature.)

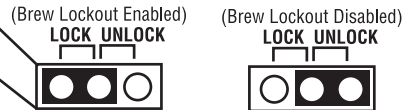
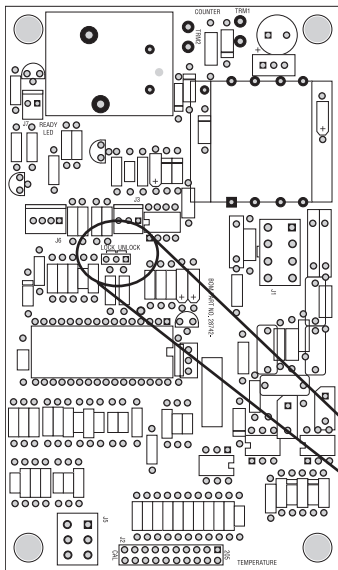

P1864

Position Shorting Jumper Across The Appropriate Set Of Pins.

1 & 2 - Any brewer that does not use a refill system.

2 & 3 - Any brewer that uses a refill system.

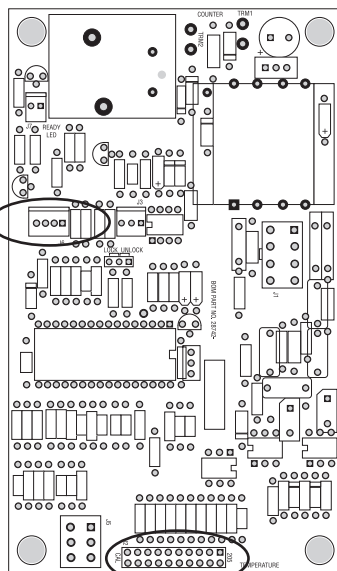
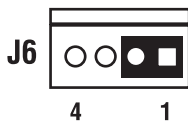

P1901

Setting Brew Temperature

Determine the desired temperature and reposition the shorting jumper across the appropriate set of pins. Each set of pins represents approximately 2.5° F. (205° F shown.)

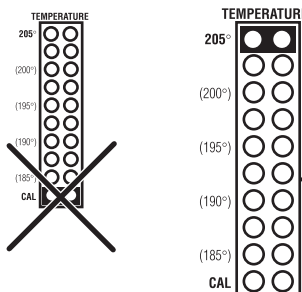

NOTICE – Do not use the Calibration setting. (bottom set of pins)

Adjusting Total Volume

BREW VOLUME SET-UP: Use the following steps when setting up the brewer for the first time.

1. Place an empty funnel in the funnel rails and an empty vessel of at least 4 gallons beneath the funnel.

2. Place the "ON/OFF" switch in the "ON", upper position.
3. Press and hold the brew start switch until you hear the brew solenoid click on-and-off three times (approximately 5 seconds). Release the switch immediately. Failure to release the switch within 2 seconds of the third click causes the volume setting to be aborted and the previous volume setting will remain in memory
4. Allow the cycle to continue until the desired amount of water is dispensed and then turn "OFF" the brewer.

The brewer is now set to dispense this amount of water for each subsequent brew cycle.

To **increase** the amount of water for each cycle place an empty funnel in the funnel rails and an empty vessel of at least 4 gallons beneath the funnel. Place the "ON/OFF" switch in the "ON", upper position. Press and hold the "START" switch until you hear the solenoid click on-and-off three times (approximately 5 seconds), then release the "START" switch immediately. Failure to release the switch within 2 seconds of the third click causes the volume setting to be aborted and the previous volume setting will remain in memory. Momentarily press and release the "START" switch once for each 3.2 ounces (approximate) of water to be added to the prior setting and allow the cycle to finish.

To **decrease** the amount of water for each cycle place an empty funnel in the funnel rails and an empty decanter or graduated vessel beneath the funnel. Place the "ON/OFF" switch in the "ON", upper position. Momentarily press and release the "START" switch once for each 3.2 ounces (approximate) of water to be removed from the existing setting. Press and hold the "START" switch until you hear the solenoid click on-and-off three times (approximately 5 seconds), then release the "START" switch immediately (failure to release the switch within 2 seconds of the third click causes the volume setting to be aborted and the previous volume setting will remain in memory) and allow the cycle to finish.

TROUBLESHOOTING

A troubleshooting guide is provided to suggest probable causes and remedies for the most likely problems encountered. If the problem remains after exhausting the troubleshooting steps, contact the Bunn-O-Matic Technical Service Department.

- Inspection, testing, and repair of electrical equipment should be performed only by qualified service personnel.
- All electronic components have 120 volt ac and low voltage dc potential on their terminals. Shorting of terminals or the application of external voltages may result in board failure.
- Intermittent operation of electronic circuit boards is unlikely. Board failure will normally be permanent. If an intermittent condition is encountered, the cause will likely be a switch contact or a loose connection at a terminal or crimp.
- Solenoid removal requires interrupting the water supply to the valve. Damage may result if solenoids are energized for more than ten minutes without a supply of water.
- The use of two wrenches is recommended whenever plumbing fittings are tightened or loosened. This will help to avoid twists and kinks in the tubing.
- Make certain that all plumbing connections are sealed and electrical connections tight and isolated.
- This brewer is heated at all times. Keep away from combustibles.

WARNING

- Exercise extreme caution when servicing electrical equipment.
- Unplug the brewer when servicing, except when electrical tests are specified.
- Follow recommended service procedures.
- Replace all protective shields or safety notices.

Before troubleshooting this brewer, check for the following:

A. Control Board

Locate J6 connector on control board. If jumper is across pins 1 & 2, board is set up to operate tea brewer which does not use a refill system. See page 7 for proper jumper location.

- B. Also make sure before servicing brewer that voltage is present at control board. Check for voltage across pins 1 & 7 of the eight pin J1 connector (black and white wires). If voltage is present, proceed with testing. If voltage is not present, check wiring and voltage at socket. Correct the problem and retest before proceeding with testing.

TROUBLESHOOTING (cont.)

BREWING CIRCUIT

PROBLEM	PROBABLE CAUSE	REMEDY
Ready light flashing	1. Brewer has shut down due to malfunction.	Refer to <i>Diagnostic Chart</i> for information. See page 13
Brew cycle will not start	1. No water	Water lines and valves to the brewer must be open.
	2. No power or incorrect voltage to the brewer	Check for voltage across the black and white terminals at the terminal block.
	3. ON/OFF switch not in the "ON" position	The indicator lamp must be lit.
	4. Start Switch	Refer to <i>Service - Start Switch</i> for testing procedures. See page 18
	5. Low water temperature (Brew lockout is enabled)	Allow brewer to heat until ready lamp is lit, or disable the brew lockout feature. See page 7
	6. Brew solenoid valve	Refer to <i>Service - Brew Solenoid Valve</i> for testing procedures. See page 15
	7. Control Board	Attach a voltmeter to terminals J1-1 & J1-7 of the control board. Connect the brewer to the power source. Voltage should be present. Disconnect the brewer from the power source. Attach a voltmeter to terminals J1-1 and J1-8. Reconnect the brewer to the power source. With the ON/OFF Switch in the "ON" position, voltage should be present. It should not be present in the "OFF" position. If these readings are not correct, replace the control board assembly. See page 21

TROUBLESHOOTING (cont.)

BREWING CIRCUIT (cont.)

PROBLEM

Consistently low beverage level in the dispenser or beverage overflows dispenser

PROBABLE CAUSE

1. Brew volume
2. Lime build up
3. Brew Solenoid Valve
4. Strainer/Flow Control

REMEDY

Refer to *Adjustments and Optional Settings* to set brew volume. See page 7. Using a stop watch or second hand, time the length of the brew cycle. Record this time inside the top lid. If service is ever needed again, use the time as reference to determine if time has changed.

Inspect the sprayhead tube and sprayhead for excessive lime deposits. Delime as required.

Refer to *Service - Brew Solenoid Valve* for testing procedures. See page 15

A) Direction of flow arrow must be pointing towards brewer.

B) Remove strainer/flow control and check for obstructions. Clear or replace.

Dripping from sprayhead

1. Lime build up
2. Brew Solenoid Valve

Inspect the tank assembly for excessive lime deposits. Delime as required.

Refer to *Service - Brew Solenoid Valve* for testing procedures. See page 15

TROUBLESHOOTING (cont.)

BREWING CIRCUIT (cont.)

PROBLEM	PROBABLE CAUSE	REMEDY
Weak beverage	1. Sprayhead	A seven-hole stainless steel sprayhead must be used for proper extraction.
	2. Water temperature	Place an empty brew funnel on an empty vessel of at least 4 gallons beneath the sprayhead. Initiate brew cycle and check the water temperature immediately below the sprayhead with a thermometer. The reading must not be less than 5°F (3°C) below set temperature. Adjust the temperature setting to increase the water temperature. Refer to <i>Adjustments and Optional Settings</i> . See page 7
	3. Filter type	BUNN® paper filters must be used for proper extraction.
	4. Funnel loading	The BUNN® paper filter must be centered in the funnel and the bed of tea leaves leveled by shaking gently.
Drip out time too long	1. Funnel Tip	The brew funnel should be cleaned thoroughly before each brew cycle to lessen the chance of tea leaf particles clogging the funnel tip.
Dry tea leaves remain in the funnel	1. Sprayhead	Make sure sprayhead is present and holes are clear and unobstructed. There should be seven separate streams of water coming out of the sprayhead.
	2. Funnel loading	The BUNN® paper filter must be centered in the funnel and the bed of tea leaves leveled by shaking gently.

TROUBLESHOOTING (cont.)

HEATING CIRCUIT (cont.)

PROBLEM

Water does not heat to proper temperature

IMPORTANT: Make sure no temperature tests are taken before the ready light is "ON". Tank temperature must be stabilized before readings are taken.

Spitting or excessive steaming

Brewer is making unusual noises

PROBABLE CAUSE

1. Water not touching temperature probe

2. Temperature Probe

3. Limit Thermostat

4. Tank Heater

1. Lime build up on temperature probe, tank or tank heater

2. Temperature Probe

3. Control Board

1. Plumbing lines

2. Water supply

3. Lime build up

REMEDY

Remove probe and grommet. Look into hole on tank lid. Water must be within one inch from top of tank.

Refer to *Service* - Temperature Probe for testing procedures. See page 20

Refer to *Service* - Limit Thermostat for testing procedures. See page 16

Refer to *Service* - Tank Heater for testing procedures. See page 19

Inspect probe and tank assembly for excessive lime deposits. Delime as required.

Refer to *Service* - Temperature Probe for testing procedures. See page 20

Set the temperature to 205°F (96°C). Let tank temperature stabilize. If temperature in tank is above temperature setting by more than 7°F (4°C), replace the control board. See page 21

Plumbing lines should not rest on the counter top.

The brewer must be connected to a cold water supply.

Remove the tank lid and clean inside of tank with a deliming agent, if necessary.

DIAGNOSTICS

Intermittent flashing of the READY indicator indicates that a fault exists. Count the number of flashes between pauses and use this chart as a guide to investigating the fault.

FLASHES	CAUSE	THINGS TO CHECK
1	Dry Plug - In Fault - Sheath of temperature probe dry for 10 minutes after power-up	Water Pressure (Is water shut off?) Temperature probe wiring Fill valve wiring, function, & strainer Green wire between tank and circuit board
2	Low Tank Level Fault - Level probe dry for 7 minutes after fill valve is energized	Water pressure (Is water shut off?) Shorting pin on J6 connector of control board not on correct set of pins (See page 7) Level probe wiring Temperature probe wiring Fill valve wiring, function, & strainer
3	Low Water Temperature Fault - Sensor in tank is calling for heat for 30 minutes or more	Tank heater wiring & function Temperature probe wiring
4	Tank Sensor Disagreement - Level probe detects water, but dry plug-in probe dry	Temperature probe wiring Level probe wiring Green wire between tank and circuit board
5	Temp Sensor Out-of-Range - High	Sensor not connected to circuit board
6	Temp Sensor Out-of-Range - Low	Sensor wires shorted together or to chassis

SERVICE

This section provides procedures for testing and replacing various major components used in this brewer should service become necessary. Refer to *Troubleshooting* for assistance in determining the cause of any problem.

WARNING - Inspection, testing, and repair of electrical equipment should be performed only by qualified service personnel. The brewer should be disconnected from the power source when servicing, except when electrical tests are required and the test procedure specifically states to plug-in the brewer.

COMPONENT ACCESS

WARNING - Disconnect the brewer from the power source before the removal of any panel or the replacement of any component.

All components are accessible by the removal of the top cover and rear access panel.

The top cover is attached with four #6-32 screws. Removal of the top cover will allow access to ON/OFF switch, Start switch, limit thermostat, temperature probe, control board and tank heater.

The rear access panel is attached with six #8-32 screws. Removal of the rear panel will allow access to the needle valve.

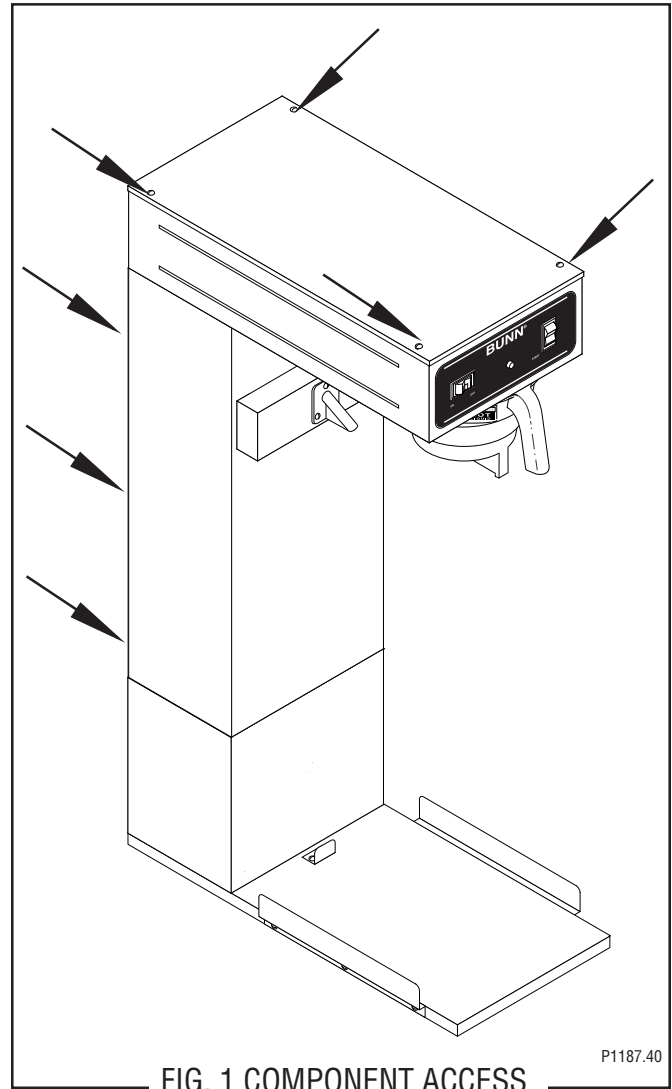

Contents

Brew Solenoid Valve	15
Limit Thermostat	16
ON/OFF Switch	17
START Switch	18
Tank Heater	19
Temperature Probe	20
Control Board	21
Wiring Diagrams	22

SERVICE (cont.)

BREW SOLENOID VALVE

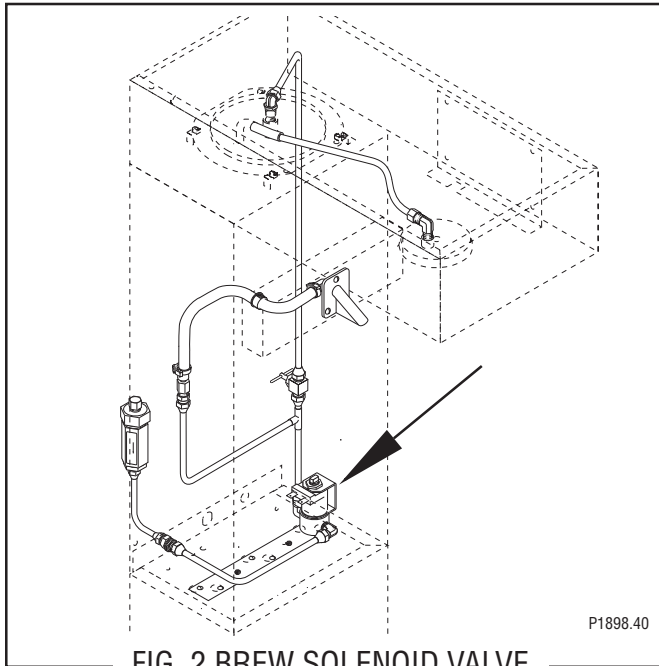

FIG. 2 BREW SOLENOID VALVE

Location:

The brew solenoid valve is mounted on the left side in the bottom rear of the brewer.

Test Procedures:

1. Disconnect the brewer from the power source.
2. Disconnect the white and white/green wires from the solenoid valve. With the ON/OFF switch in the "ON" upper position press the start switch.
3. With a voltmeter, check the voltage across the white and white/green wires. Connect the brewer to the power source. The indication must be 120 volts ac for two wire 120 volt models.
4. Disconnect the brewer from the power source,

If voltage is present as described, proceed to #5

If voltage is not present as described, refer to *Wiring Diagrams* and check brewer wiring harness.

5. Check for continuity across the solenoid valve coil terminals.

If continuity is present as described, reconnect the white and white/green wires to the solenoid valve.

If continuity is not present as described, replace the solenoid valve.

6. Check the solenoid valve for coil action. Connect the brewer to the power source. With ON/OFF switch in the "ON" upper position press start switch and listen carefully in the vicinity of the solenoid valve for a "clicking" sound as the coil magnet attracts.
7. Disconnect the brewer from the power source.

If the sound is heard as described and water will not pass through the solenoid valve, there may be a blockage in the water line before the solenoid valve or, the solenoid valve may require inspection for wear, and removal of waterborne particles.

If the sound is not heard as described, replace the solenoid valve.

Removal and Replacement:

1. Remove all wires from solenoid valve.
2. Turn off the water supply to the brewer.
3. Disconnect the water lines to and from the solenoid valve.
4. Remove the two #8-32 keps nuts holding the mounting bracket to the brewer base.
5. Lift out the bracket.
6. Remove the two #10-32 slotted-head screws holding the solenoid valve to the mounting bracket.
7. Securely install the new solenoid valve to the mounting bracket.
8. Attach the mounting bracket to the brewer base.
9. Securely fasten the water lines to and from the solenoid valve.
10. Refer to Fig. 3 when reconnecting the wires.

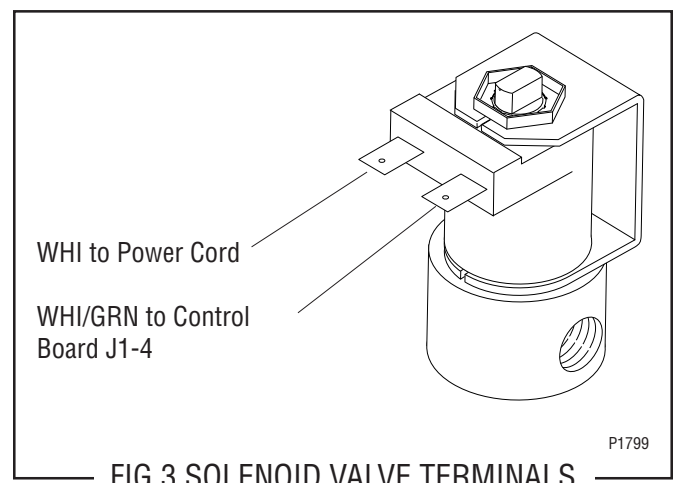

FIG.3 SOLENOID VALVE TERMINALS

SERVICE (cont.)

LIMIT THERMOSTAT

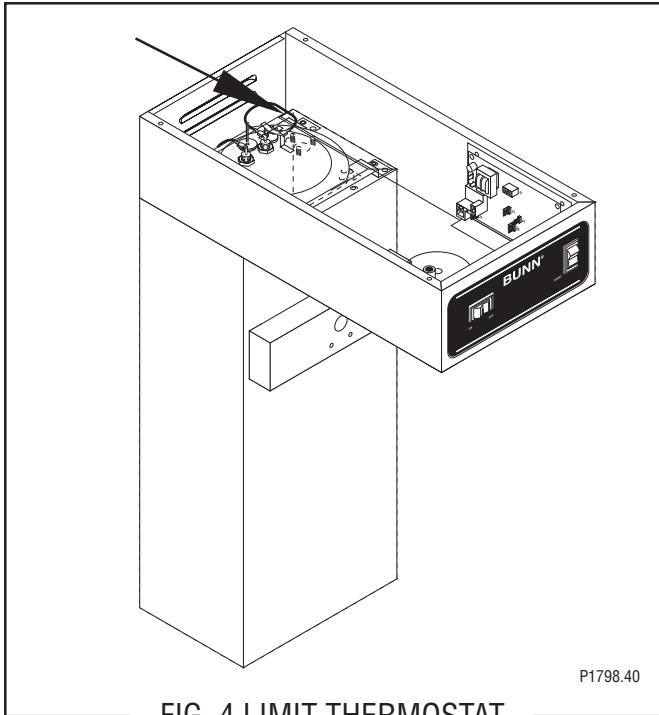

FIG. 4 LIMIT THERMOSTAT

Location:

The limit thermostat is located inside the hood on the tank lid.

Test Procedure:

1. Disconnect the brewer from the power source and remove the blue wire from the limit thermostat.
2. With a voltmeter, check the voltage across the blue wire removed from the limit thermostat and the white wire on the tank heater terminal. Connect the brewer to the power source. The indication must be 120 volts ac for two wire 120 volt models.
3. Disconnect the brewer to from the power source.

If voltage is present as described, reconnect the blue wire and proceed to #4.

If voltage is not present as described, refer to the *Wiring Diagrams* and check the wiring harness.

4. Remove the black wire from the limit thermostat.

5. With a voltmeter, check the voltage across the exposed terminal of the limit thermostat and the white wire on the tank heater terminal. Connect the brewer to the power source. The indication must be 120 volts ac for two wire 120 volt models.
6. Disconnect the brewer from the power source.

If voltage is present as described, reconnect the black wire to the limit thermostat. The limit thermostat is operating properly.

If voltage is not present as described, replace the limit thermostat.

Removal and Replacement

1. Remove both wires from the limit thermostat terminals.
2. Carefully slide the limit thermostat out from under the retaining clip.
3. Carefully slide the new limit thermostat into the retaining clip.
4. Refer to Fig. 5 when reconnecting the wires.

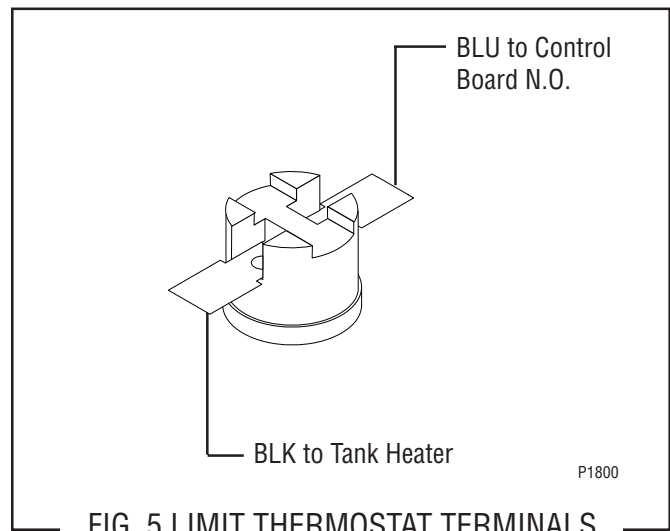

FIG. 5 LIMIT THERMOSTAT TERMINALS

SERVICE (cont.)

ON/OFF SWITCH

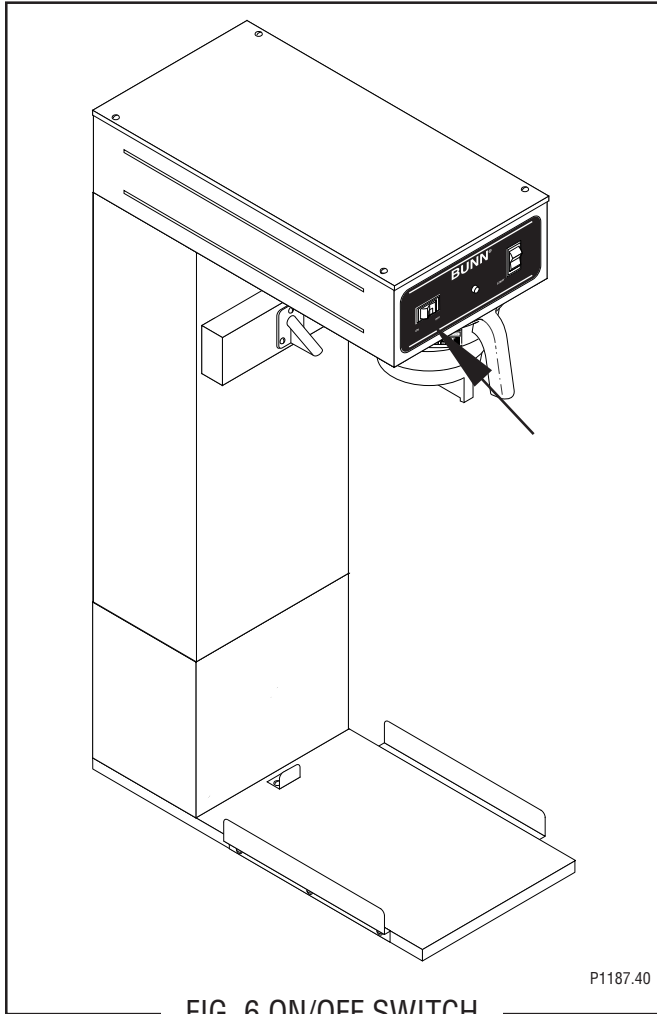

FIG. 6 ON/OFF SWITCH

Location:

The ON/OFF switch is located in the front of the hood, above and to the left of the brew funnel.

Test Procedure:

1. Disconnect the brewer from the power source.
2. Remove the black and white/violet wires from the switch terminals.
3. With a voltmeter, check the voltage across the black wire removed from the ON/OFF switch and the white wire remaining on the switch terminal.
4. Connect the brewer to the power source. The indication must be 120 volts ac for two wire 120 volt models.
5. Disconnect the brewer from the power source.

If voltage is present as described, proceed to #6.
If voltage is not present as described, refer to the *Wiring Diagrams* and check the wiring harness.

6. Check for continuity across the center and end terminals of the top row when the switch is in the "ON" position.

If continuity is present as described, replace the wires, the switch is operating properly.

If continuity is not present as described, replace the switch.

Removal and Replacement:

1. Remove the wires from the switch terminals.
2. Compress the clips inside the hood and gently push the switch through the opening.
3. Push the new switch into the opening and spread the clips to hold the switch captive in the hood.
4. Refer to FIG. 7 when reconnecting the wires.

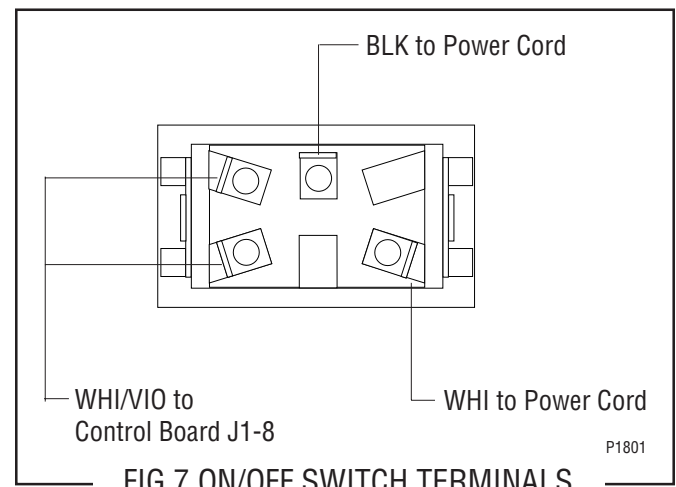
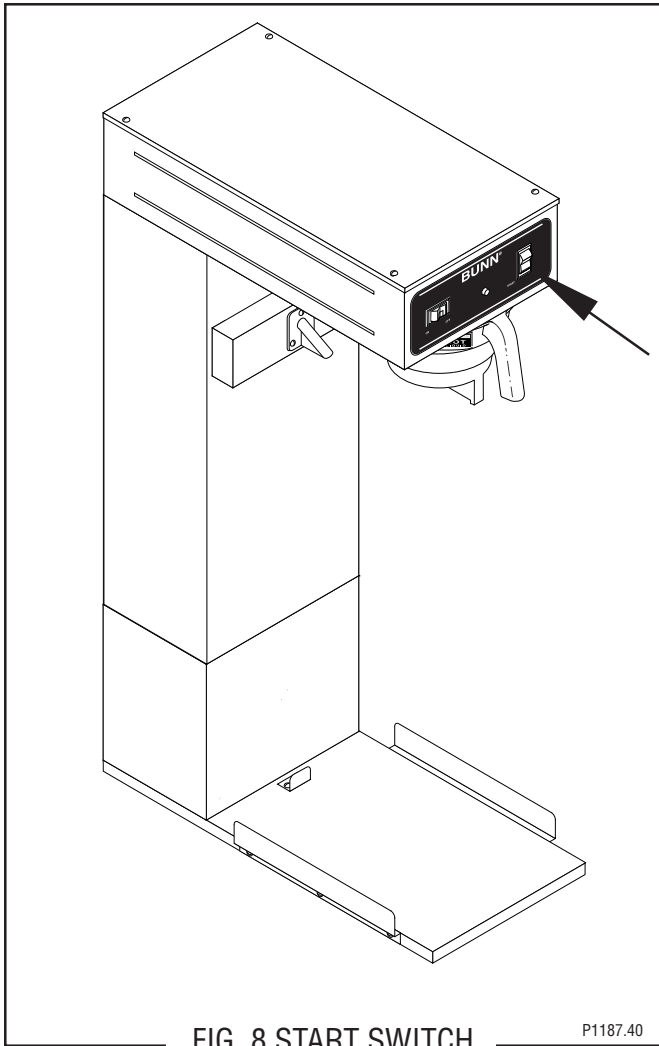

FIG.7 ON/OFF SWITCH TERMINALS

SERVICE (cont.)

START SWITCH



Removal and Replacement:

1. Remove the wires from the switch terminals.
2. Compress the clips inside the hood and gently push the switch through the opening.
3. Push the new switch into the opening and spread the clips to hold the switch captive in the hood.
4. Refer to Fig. 9 when reconnecting the wires.

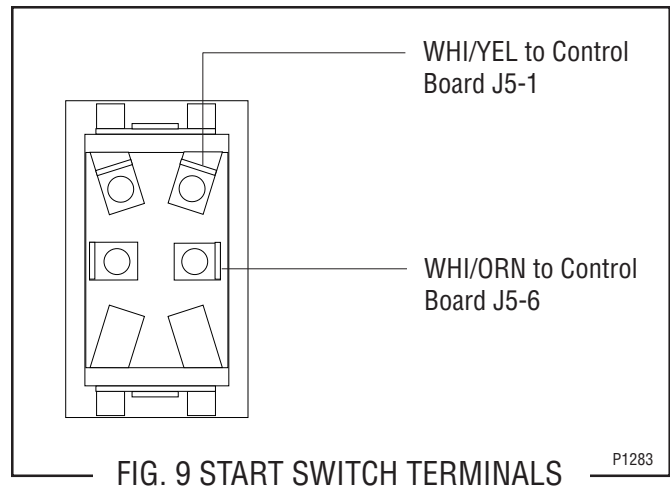

Location:

The start switch is located in the front of the hood, above and to the right of the brew funnel.

Test Procedure:

1. Disconnect the brewer from the power source.
2. Remove the wires from the terminals.
3. Check for continuity across the two terminals on the side of the switch from which the wires were removed, when the switch is held in the lower position. Continuity must not be present across these terminals in the upper position.

If continuity is present as described, the switch is operating properly.

If continuity is not present as described, replace the switch.

SERVICE (cont.)

TANK HEATER

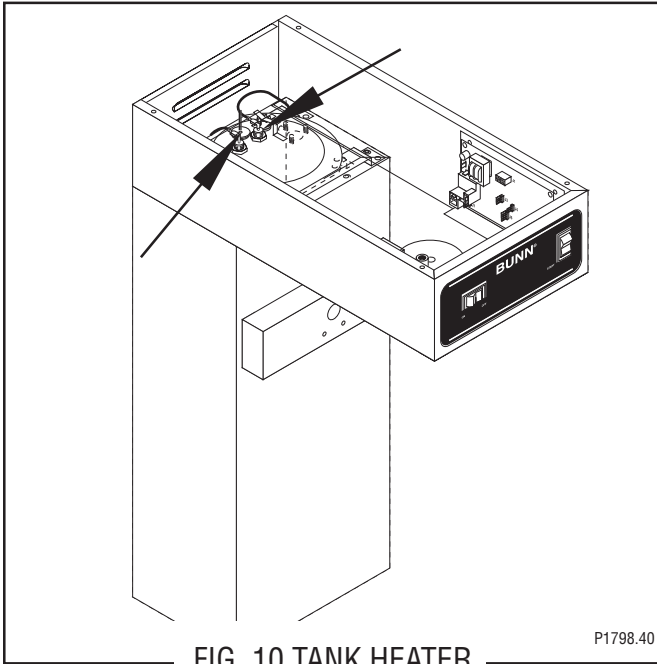

Location:

The tank heater is located inside the tank and secured to the tank lid.

Test Procedures:

1. Disconnect the brewer from the power supply.
2. With a voltmeter, check the voltage across the black and white wires. Connect the brewer to the power source. The indication must be 120 volts ac for two wire 120 volt models .
3. Disconnect the brewer from the power source.

If voltage is present as described, proceed to #4

If voltage is not present as described, refer to the *Wiring Diagrams* and check wiring harness.

4. Disconnect the black wire and the white wire from the tank heater terminals.
5. Check for continuity across the tank heater terminals.

If continuity is present as described, reconnect the wires, the tank heater is operating properly.

If continuity is not present as described, replace the tank heater.

NOTE- If the tank heater remains unable to heat, remove and inspect heater for cracks in the sheath.

Removal and Replacement:

1. Disconnect the black wire and the white wire from the tank heater terminals.
2. Remove sprayhead and the hex nut securing the sprayhead tube to the hood. Set aside for reassembly.
3. Disconnect vent tube.
4. Remove the six #10 thread cutting screws securing the tank lid to the tank. Remove the green wire.
5. Remove the tank lid with limit thermostat, spray head tube, tank heater and vent tube.
6. Remove the two hex nuts securing the tank heater to the tank lid. Remove tank heater with gaskets and discard.
7. Install new tank heater with gaskets on the tank lid and secure with two hex nuts.
8. Install tank lid with limit thermostat, sprayhead tube, tank heater and vent tube and the green wire using six #10 thread cutting screws.
9. Secure sprayhead tube to hood using a hex nut.
10. Install sprayhead.
11. Connect vent tube to fitting.
12. Reconnect the wires to the limit thermostat, tank heater. See *Limit Thermostat* section in this manual when reconnecting wires.
13. Refer to Fig.11 when reconnecting the tank heater wires.

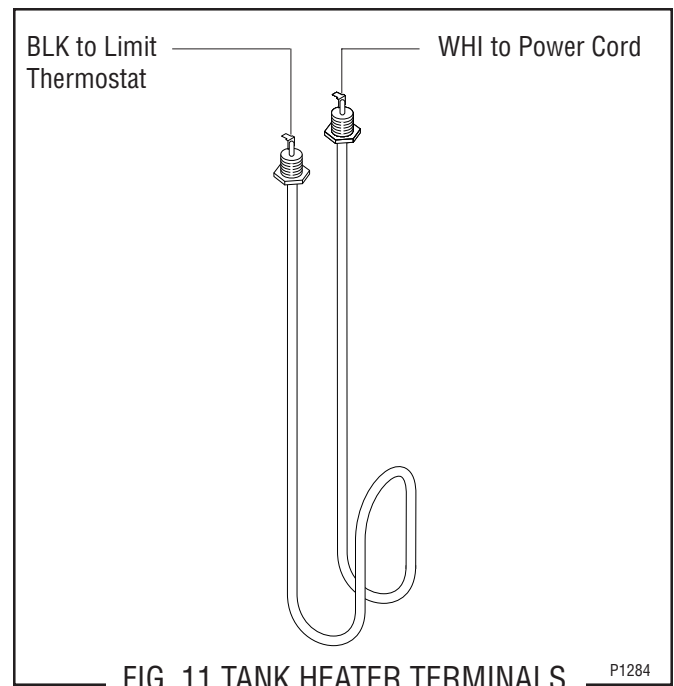

SERVICE (cont.)

TEMPERATURE PROBE

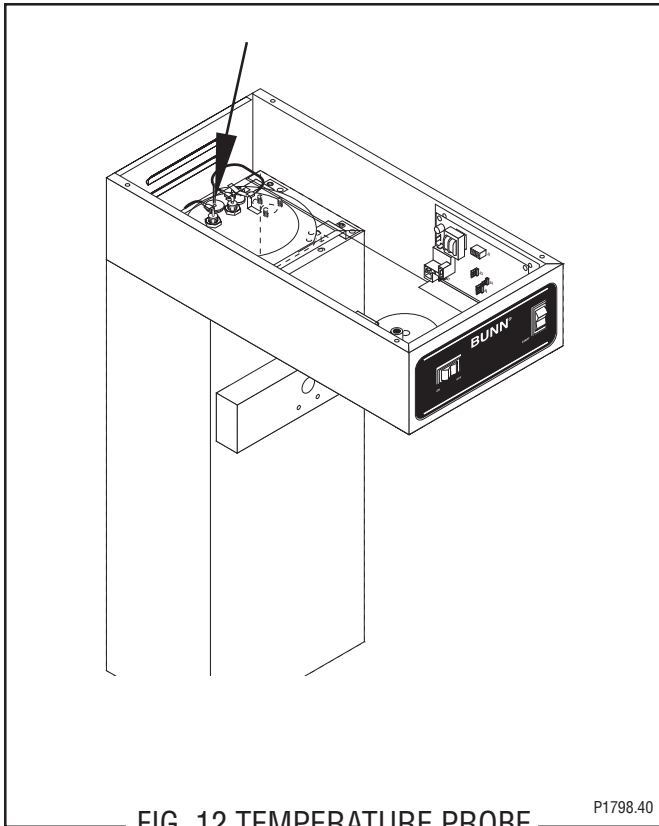

FIG. 12 TEMPERATURE PROBE

Location:

The temperature probe is located on the tank rear of the tank lid, behind the tank heater.

Test Procedures:

1. Disconnect the brewer from the power source.
2. Remove the temperature probe from the grommet.
3. Submerge the probe in a water bath of approximately 70°F (21°C).
4. Connect an ohmmeter to pins 2 and 3 of the J-5 connector on the control board. The indications should be as follows:
 - a) 15.3k \pm 2k OHMS at 60°F (15°C)
 - b) 11.8k \pm 2k OHMS at 70°F (21°C)
 - c) 9.3k \pm 2k OHMS at 80°F (27°C)

If resistance is present as described, the temperature probe is operating properly.

If resistance is not present as described, replace the temperature probe.

Removal and Replacement:

1. Disconnect the brewer from the power source.
2. Pull the existing probe from the tank lid.
3. Cut the white and black wires close to the probe and discard the probe. **Do not** disconnect these wires from the electronic control assembly.
4. On the new probe, cut the white and black wires near the terminals. Discard the terminals. Insert the new probe into the tank assembly.
5. Insert the white wire from the new probe and the white wire from the electronic control assembly into one of the UR connectors provided with the replacement kit, and carefully crimp the connector.
6. Insert the black wire from the new probe and the black wire from the electronic control assembly into the remaining UR connector provided with the replacement kit, and carefully crimp the connector.
7. Refer to Fig. 13 when reconnecting the wires.

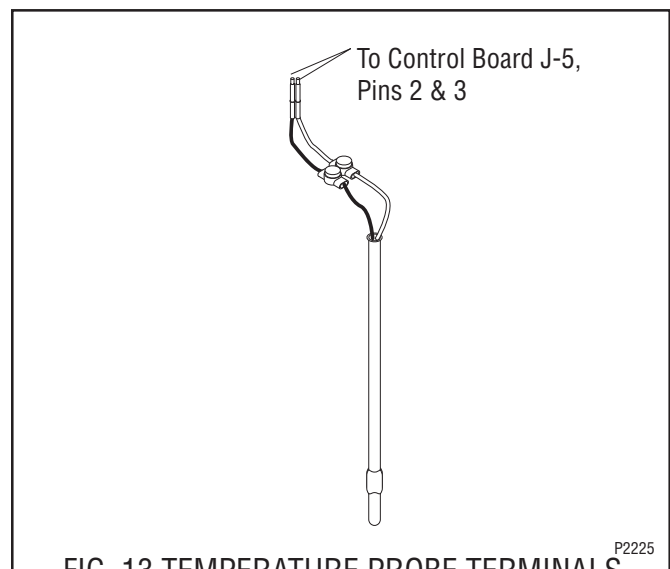

FIG. 13 TEMPERATURE PROBE TERMINALS

SERVICE (cont.)

CONTROL BOARD

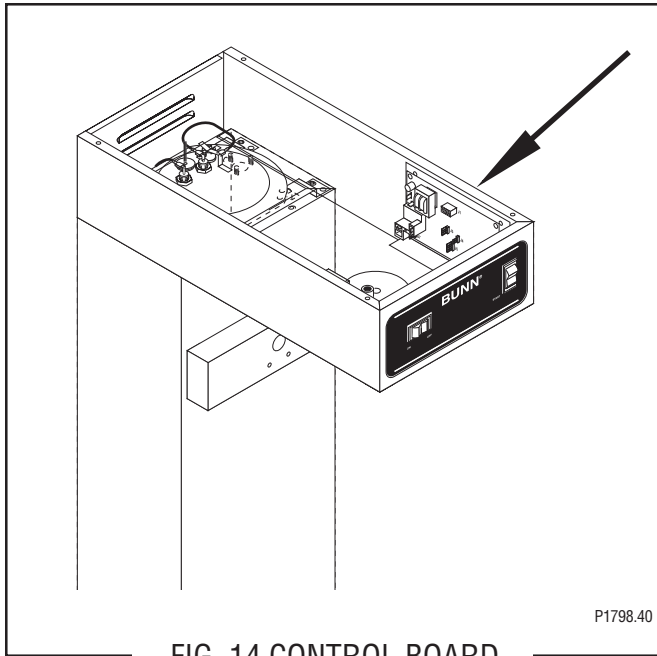

FIG. 14 CONTROL BOARD

Location:

The Control Board is located inside the hood on the right front behind the Start switch.

Test Procedure:

The test procedures for the control board will vary depending upon the problems experienced by the brewer. Refer to the Troubleshooting guide beginning on page 8. The troubleshooting guide is divided into three sections, Refill Circuit, Heating Circuit, and Brewing Circuit.

Removal and Replacement:

1. Disconnect the black wire (COM) to the cord set.
2. Disconnect the blue wire (N.O.) to the limit thermostat.
3. Disconnect the 8-pin connector (J-1) and the 6-pin connector (J-5) from the main wiring harness.
4. Disconnect the 2-pin connector (J-7) from the ready indicator LED.

5. Remove the four #6-32 screws securing the control board to the component mounting bracket.
6. Remove the four spacers from the old control board and attach them to the new control board.
7. Install a new control board and secure with the four #6-32 screws to the component mounting bracket.
8. Connect the 2-pin connector from the ready indicator LED.
9. Connect the 8-pin connector and the 6-pin connector from the main wiring harness.
10. Connect the blue wire (N.O.) from the limit thermostat and the black wire (COM) from the cord set.
11. Refer to *Adjustments and Optional Settings* to program the new control board.

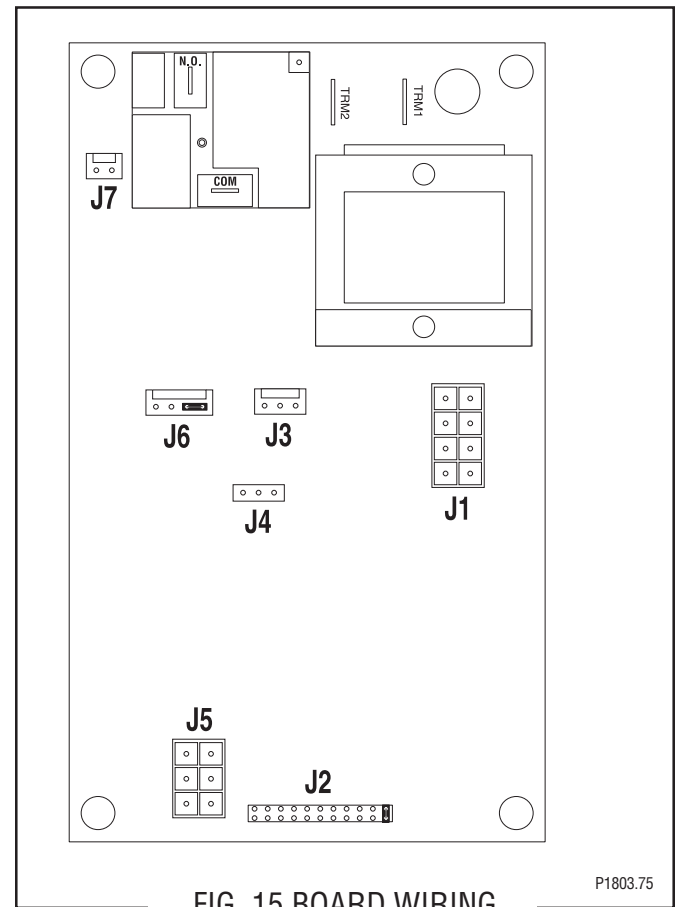
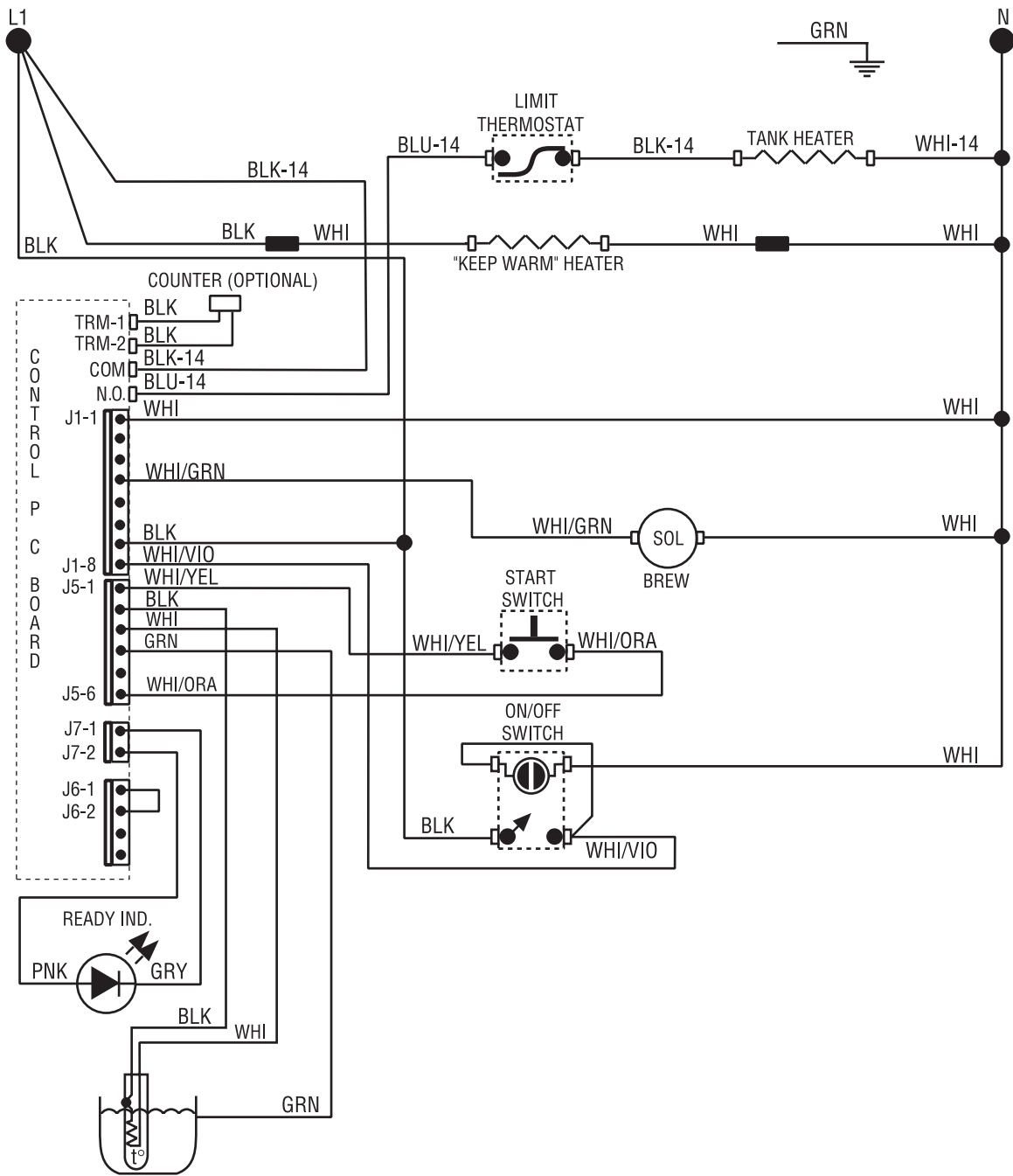

FIG. 15 BOARD WIRING

SCHEMATIC WIRING DIAGRAM TU3Q-EZ



**120V AC 2 WIRE
SINGLE PHASE**